

Contents	Page
Introduction	2
The Partner Colleges	
<i>Map of Region</i>	3
<i>Easton College</i>	4
<i>Otley College</i>	5
<i>The College of West Anglia</i>	6
<i>Writtle College</i>	7
Qualification Tree and Explanation	8 – 9
Entry Requirements and Application procedures	10
The Course Guide:	
Agriculture and Food Production:	12 - 23
<i>Course index</i>	
<i>Course detail</i>	
Animal:	24 – 37
<i>Course index</i>	
<i>Course detail</i>	
Business:	38 - 46
<i>Course index</i>	
<i>Course detail</i>	
Countryside Management and Environmental Conservation:	47 - 59
<i>Course index</i>	
<i>Course detail</i>	
Design:	60 - 68
<i>Course index</i>	
<i>Course detail</i>	
Floristry:	69 - 80
<i>Course index</i>	
<i>Course detail</i>	
Horse Studies:	81 - 92
<i>Course index</i>	
<i>Course detail</i>	
Horticulture:	93 - 107
<i>Course index</i>	
<i>Course detail</i>	
Land-related Engineering:	108 - 114
<i>Course index</i>	
<i>Course detail</i>	
Sport, Leisure and Tourism:	115 - 125
<i>Course index</i>	
<i>Course detail</i>	
Veterinary Nursing:	126 - 131
<i>Course index</i>	
<i>Course detail</i>	

Land Learn

Introduction

Widening Participation in Land-Related Industries Within East Anglia

The objectives of the Land Learn project, managed jointly by the four land-based colleges in the Eastern Region, is to promote land-related industries, raise the profile of land-related courses and provide information to the public and potential students.

Land-related study can be overlooked by potential students who are not fully aware of the opportunities and career pathways available to them. The high vocational content of land-related courses allows candidates to gain both practical and technical skills within their chosen area whilst developing the business knowledge required to succeed in the world of work.

This brochure aims to list all the land-related courses within the East Anglian region, together with the modes and levels of study, progression routes and related career information. Primarily, it has been produced for use by information providers, such as careers advisors, schools and colleges, as an aid to inform potential students about land-related study. The document can be duplicated in whole, or part, to be distributed as required.

A 28-page promotional brochure entitled 'What on Earth' has also been published by Land Learn. Aimed predominately at 16 to 19 year olds, it gives a general introduction to land-related study and links to related careers. Free copies of this brochure are available on request.

Please note that although all effort has been made to provide correct information, the details given within the course guide have been compiled from secondary sources such as prospectuses, websites and course factsheets. Each college, university and learning organisation has the right to modify, replace or cancel courses without prior notice. Land Learn takes no responsibility if the information provided is incorrect or out-of-date.

Institutions are welcome to contact the Project Officer with any queries or corrections. An updated version of the guide will be produced in due course.

2005

Lisa Flecknell

Widening Participation Officer

E-mail: lisa.flecknell@writtle.ac.uk

Map of Anglia

This is a joint project between the four Land Learn colleges in East Anglia, one of a number funded by Aimhigher, HEFCE and FEFC.

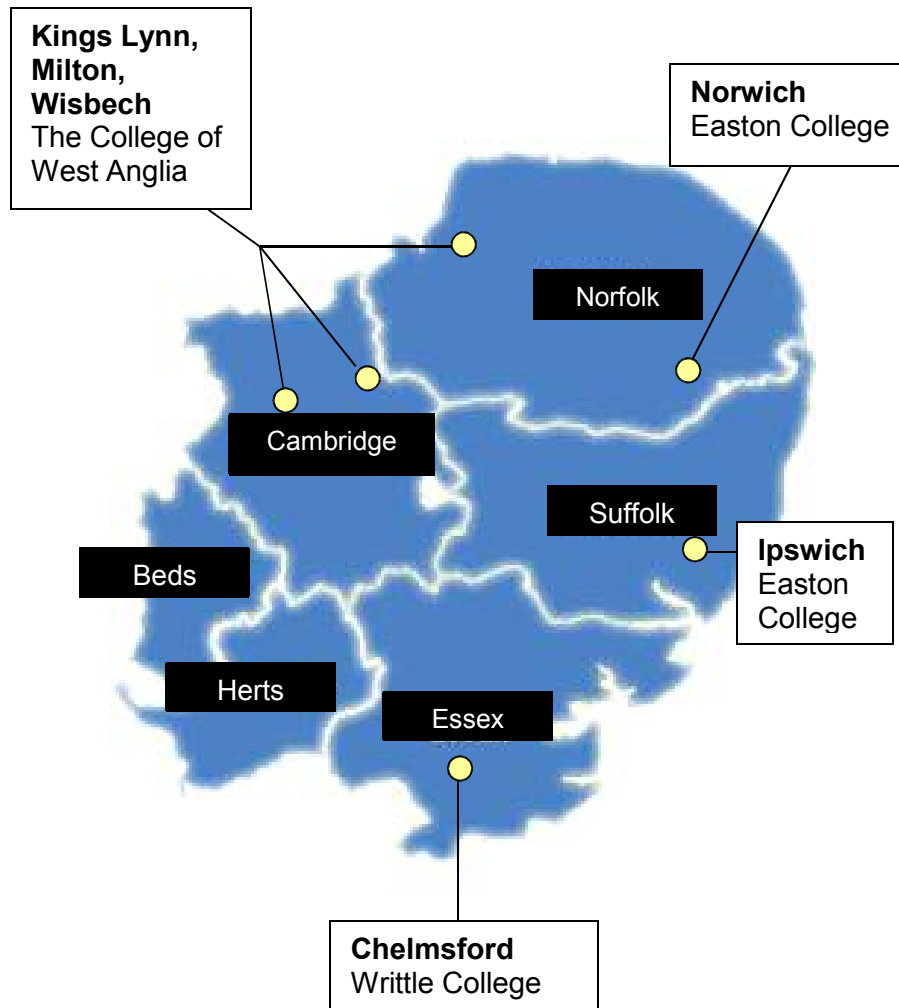



Easton College provides a broad range of training focused on land-related industries but also including sports, public services and design.

Set in an attractive 200 hectare estate, a first class range of facilities are available to all students. These include a new state of the art teaching building with laboratories and floristry rooms, animal care centre, deer park, farm livestock enterprises, equestrian yard, horticultural units, agricultural machinery workshops and design studios.

Students at Easton have a lively social life in a friendly and relaxed atmosphere. The Sports and Conference Centre has a large sports hall, new all-weather outdoor courts and a well-equipped gym as well as a bar area with TV screen. Norwich is great for shopping and socialising and a frequent venue for well-known bands.

A wide range of full-time, part-time and short courses are offered throughout the curriculum, and the College's Higher Education programmes are offered in partnership with APU (Anglia Polytechnic University). Full-time students also get the opportunity to undertake additional qualifications that compliment their programme of study, such as PA spraying certificates, forklift truck training or sport coaching awards.

Easton College has recently been awarded Centre of Vocational Excellence (CoVE) status in Land Management. This will allow new courses to be developed related to all aspects of managing the countryside, including conservation and environmental issues, sustainability and diversification.

Strong links with industry underpin all that goes on at the College so that courses reflect the needs of industry, and students are well-equipped to take their place in a skilled workforce.

Easton College

Easton
Norwich
Norfolk
NR9 5DX

Tel: 01603 731200
E-mail: info@easton.ac.uk
www.easton-college.ac.uk



Otle College offers students the opportunity to learn, train, socialise and have fun in a great atmosphere that brings learning to life. It's the choice of thousands of students in East Anglia every year.

Our aim is to help our students succeed. Success to us means gaining the skills and knowledge to get a job, or the opportunity to progress onto another course.

The College is constantly changing and improving. Recent refurbishments include a complete overhaul of the student common room and dining facilities. Plans are in place to expand both the Equine and Construction provision at the College, providing both indoor and outdoor working areas.

Our FoodSkills Centre, recently awarded CoVE (Centre of Vocational Excellence) status, has also undergone building work to expand the kitchen and food processing facilities. All of which have been built to the latest high quality industry standards.

We are located in the heart of rural Suffolk but just 10 minutes north of Ipswich. London and Norwich are easily accessible by train and Ipswich and the surrounding areas offer students the opportunity of a vibrant social life.

In addition to the Land Learn courses, Otle also offers a programme of Leisure Learning with courses ranging from film appreciation to bee keeping and reflexology to sound engineering.

Otle College

Charity Lane
Otle
Ipswich
Suffolk
IP6 9EY

Tel: 01473 784200

E-mail: info@otleycollege.ac.uk

www.otleycollege.ac.uk



Whether you have just left school, or want to combine work and returning to full-time study, the College of West Anglia's two land-based centres, in Milton and Wisbech, are a great place to learn.

Our Milton and Wisbech Centres offer full and part-time land-based courses, including Equine Studies, Horticulture, Floristry, Garden Design, Countryside Management and Agriculture. The Milton Centre has recently undergone a lot of modernisation including a new teaching block and canteen, while our Wisbech Centre has recently built a new American barn stables.

Even though the College of West Anglia, with its main site in King's Lynn, is one of the largest in the East Anglian region, each site has its own unique identity, allowing you to study within a small and friendly atmosphere. Strong transport links are in place between each site and the nearest towns, so you can easily reach any of the wealth of attractions and social activities in the area.

Our land-based courses can be anything up to 70% practical and a strong emphasis is placed on students gaining hands-on experience. Opportunities for work placements have been developed both locally and internationally – with students working as far away as Australia, the Philippines and South Africa. Links have also been forged with the racing community in Newmarket. The College prides itself on its flexibility towards students and their needs, running many courses on a part-time basis and taking learning into the community. For up-to-date information on the wide range of land-based courses that are offered, please call our Milton or Wisbech Centres

Milton Centre

Landbeach Road, Milton, Cambridgeshire, CB4 6DB

Tel: 01223 860701

Email: miltonstaff@col-westanglia.ac.uk

www.col-westanglia.ac.uk

Wisbech Centre

Newcommon Bridge, Wisbech, Cambridgeshire, PE12 2SL

Tel: 01945 581024

Email: wisbechstaff@col-westanglia.ac.uk

www.col-westanglia.ac.uk

For information about the wide range of non-land-based courses offered by the College of West Anglia, please contact the College's main site in King's Lynn

King's Lynn Centre

Tennyson Avenue, King's Lynn, Norfolk, PE30 2QW

Tel: 01553 761144

Email: enquiries@col-westanglia.ac.uk

www.col-westanglia.ac.uk



Writtle COLLEGE

a partner institution of the University of Essex

Writtle is a higher education college, which also runs a variety of FE and short courses. With over 100 years experience as a provider of education, Writtle has a reputation for excellence. Links have been forged with the University of Essex and Shuttleworth College in Bedfordshire is managed by Writtle.

Writtle has a busy social scene. A student bar, canteen, accommodation for 400 people, fitness centre and sport facilities are all available on campus.

The Students' Union organises many social events throughout the year, such as Rag Week, and Hylands Park, home to the famous V Festival, is within walking distance of the College grounds. Chelmsford caters well for students with its range of pubs, clubs, shops and social activities.

Writtle College Busy Bees Nursery is available to students with young children. The Lordship Science Centre has well equipped teaching laboratories and lecture theatres and the College has taken a major initiative forward through the creation of its environmentally-friendly Rural Business Centre. The centre was designed to explore the benefits of adopting an ecological approach to building and is an example of an energy efficient, super-insulated building.

Writtle has many international links and students, who have the opportunity to spend a year in industry, could find themselves working around the world. All students who wish to undertake work experience are encouraged to do so and the College has many contacts with businesses in the area.

Shuttleworth is renowned for its friendly atmosphere, caring staff and impressive environment; the College offers innovative courses in a relaxed, stylish setting. Courses currently on offer range from work-based training and leisure programmes to full-time courses up to higher education level.

Writtle College

Chelmsford
Essex
CM1 3RR

Tel: 01245 424200
E-mail: info@writtle.ac.uk
www.writtle.ac.uk

Qualification Tree

An introduction to the main qualifications featured in this brochure.

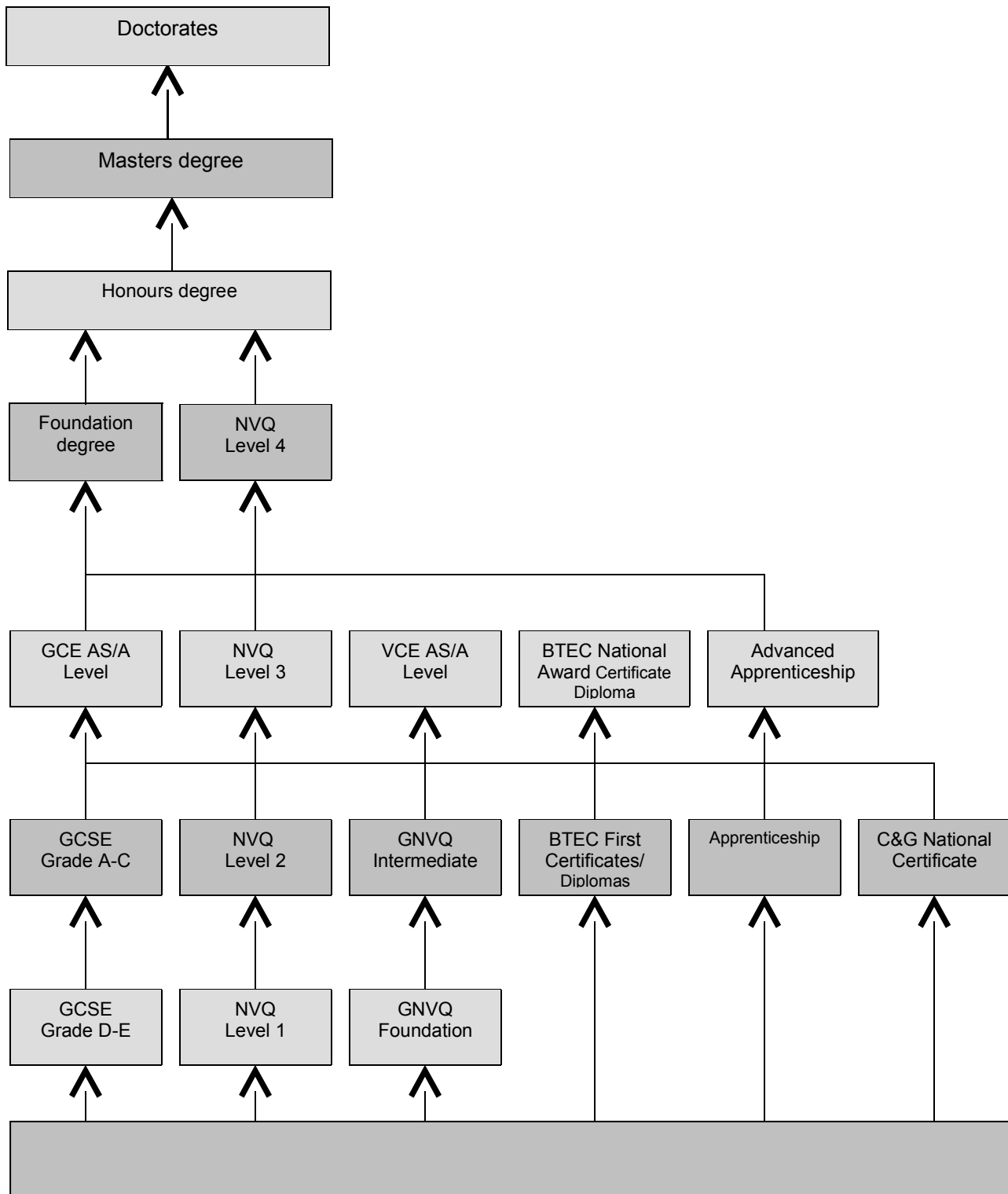

Qualifications Explained

National Vocational Qualifications

National Vocational Qualifications (NVQs) are practical qualifications which test the skills and knowledge required to carry out a particular job. NVQs are available at five levels, offering qualifications for individuals who have just started their career up to those already working in supervisory positions.

City & Guilds National Certificate

These one-year introductory courses are ideal for students who have little experience in a chosen field. By the end of the programme the students should have developed high standards of practical skills and may be able to progress to the City & Guilds Advanced National Certificate or possibly the BTEC National Certificate or Diploma.

City & Guilds Advanced National Certificate

The practical content of the Advanced National Certificate is substantial, with a great deal of hands-on teaching. The Advanced National Certificate is also a level 3 qualification which means that it is equivalent to A level.

BTEC First Diploma

These one year courses combine the theoretical and practical aspects of the programme area. Work experience is usually an integral part of the course. When a student has successfully completed the course it may be possible to progress onto a BTEC National Certificate / Diploma or City & Guilds Advanced National Certificate.

BTEC National Certificate/Diploma

These qualifications focus on a vocational area or occupation, making them an excellent practical alternative to AS or A levels. They are designed to provide students with the theoretical and technical skills required to work in a particular industry. When students have completed the course successfully, they will have the chance to progress to a higher level qualification.

Key Skills

These qualifications aim to develop skills relevant to the workplace and life in general. Many of the courses provide the chance to gain different levels of Key Skills qualifications in Communication, Application of Number and Information Technology. Students can also take the wider Key Skills qualifications in Working with Others, Problem-solving and Improving Own Learning and Performance.

Foundation degree (FdSc or FdA)

This is a two-year part-time programme designed to meet the needs of the employment market. Work-related skills and knowledge equip the students to get a new job or improve current job skills.

Degree (BA or BSc)

Courses with the award of BA (Bachelor of Arts) and BSc (Bachelor of Science) are all first degrees and are offered on a three year full-time basis. This course can also be studied on a part-time basis.

Entry Requirements

Each college has its own recruitment system. Potential students are usually interviewed and offered a place on the basis of previous qualifications, experience and/or discussion with either the tutor or student advisor.

If a student does not meet entry requirements to a particular course then they may be advised to join at a lower level and progress upwards.

Each college has its own entrance system for mature students. Candidates are usually offered a place on the basis of previous experience and through discussion with the tutor or student advisor, rather than formal qualification. Please contact the relevant college for an informal discussion about mature admissions and relevant courses.

Application Procedures

Short courses

Contact the college directly for up-to-date information about course availability, times, dates, entry requirements and price.

Further Education

Apply directly to a college by filling in one of their application forms. These can usually be found in the college prospectus – or can be obtained by contacting student services at the college in question.

Higher Education

Applications for some HE courses must be made through UCAS (the University and Colleges Admissions Service). Other courses can be applied for directly through the college, by filling in one of their application forms. Please contact the relevant college to find out the correct procedure for a particular course.

Fees

Each college will give information on fees and other expenses, such as course materials. Potential students should also contact their LEA (Local Education Authority) to get advice on loans, help with fees, childcare etc.

The Course Guide

Agriculture

Introduction

Agriculture provides a wide range of opportunities for people of any age, because it is such a diverse industry. The focus of farming is primarily food production and the main farm types are dairy, beef, sheep, pigs, poultry, vegetables, cereals, root crops and other cash crops.

However, the industry is also involved in non-food production for industrial development such as flax, hemp and lavender. Modern farmers manage the countryside, and this is why the emphasis nowadays is on developing farming methods that are sympathetic to plants, animals and wildlife. The protection or 'stewardship' of rural landscapes, along with an increase in organic production, are examples of how the industry is responding to public concerns.

The agricultural industry has gone through a number of dramatic changes within the last few years, not least recent changes in Common Agricultural Policy that include single farm payments, cross compliance and the offer of two environment schemes that are encouraging farmers towards more sustainable farming methods. The consequences of these changes may require farmers to change their method of production or indeed to cease production and to diversify into non production areas.

Farms are becoming ever more competitive, looking towards new ways of working and technological advances, having to balance increased yields with environmental concerns. For example organic foodstuff is becoming ever more popular; with the demand of a healthy lifestyle, consumers require their foodstuff to be of a high quality whilst low in price.

The changes to food production are requiring farmers and employees to have a new mix of skills. Food production is still the main focus, but farmers are now also gearing towards other activities such as sport, leisure, conservation and the production of alternative crops or animals.

Agricultural industries do not just focus on driving tractors but provide skills for students to progress in all levels of food production and the food chain. For example students could find themselves working with animals on a farm or working on new food products for a major supermarket chain.

As a result, the industry has a greater need for skilled employees with both business knowledge and the ability to adapt to technological changes. Potential students should be practically minded, show a high level of responsibility and be able to problem solve. Working in agriculture is not a nine-to-five job and requires flexibility.

Further Education

Qualification	Level	Course Title	Page
Foundation	Entry	<ul style="list-style-type: none"> Land-based Skills for Working Life 	14
NVQ Level 1	1	<ul style="list-style-type: none"> General agriculture Land-based operations 	15
First Diploma	2	<ul style="list-style-type: none"> Agriculture Agriculture and farm mechanisation 	16
National Certificate	2	<ul style="list-style-type: none"> Agriculture 	17
NVQ Level 2	2	<ul style="list-style-type: none"> Agriculture Agricultural crop production Livestock (pigs, poultry, sheep, cattle) 	18
National Diploma	3	<ul style="list-style-type: none"> Agriculture Agriculture and farm Mechanisation Land-based technology 	19
NVQ Level 3	3	<ul style="list-style-type: none"> Agriculture Agricultural crop production Livestock (pigs, poultry, sheep, cattle) 	20

Higher Education

Qualification	Course Title	Page
Foundation degree (Replacing HND/HNC)	<ul style="list-style-type: none"> FdSc Agriculture 	21
Degree	<ul style="list-style-type: none"> BSc (Hons) Agriculture BSc (Hons) Agriculture and the Environment BSc (Hons) Agriculture with Business Management 	22

Miscellaneous

Short and Leisure Courses	Page
<ul style="list-style-type: none"> Poultry Food Production Gamekeeping 	23

Linking subjects:

An **agriculture and food** qualification can allow progression to other subject areas

Course
<ul style="list-style-type: none"> Animal studies Conservation Equine studies Horticulture Land-related engineering

Choosing a Further Education course in Agriculture

Foundation Level

This type of course is aimed at those with little or no formal qualifications. This is an introduction to working within the agricultural industry, while continuing to develop basic educational skills.

A high level of student support is given and students are instructed in communication, numeracy and life skills.

Entry Requirements:

No formal qualifications are needed

Age:

16 years +

Must be:

Interested in agricultural industry

Areas of study may include

- Crop and livestock science and technology
- Crop and livestock production
- Agricultural machinery operation and maintenance
- Estate skills
- Workshop practice

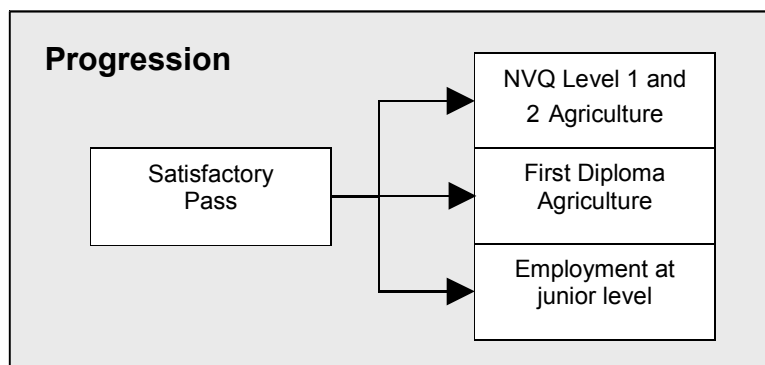

Participating institutions

Easton College

Edexcel Certificate in Skills for Working Life

Full-time: 1 year – 5 days a week in college

Otley College

Foundation Land-based

Full-time: 1 year

NVQ Level 1

Normally lasting one year, the NVQ Level 1 is designed as a basic introduction to working within the agricultural industry. This is a work-based qualification and is assessed by observation of practical activities and by building up a portfolio of evidence.

Entry Requirements:

No formal qualifications are required

Age:

16 years +

Must be:

Interested in agriculture and have a basic level of secondary education

Areas of study may include

- Estate maintenance
- Tractor driving and handling
- Harvesting
- Livestock production
- Crop production
- Machinery maintenance
- Health and safety
- Communication

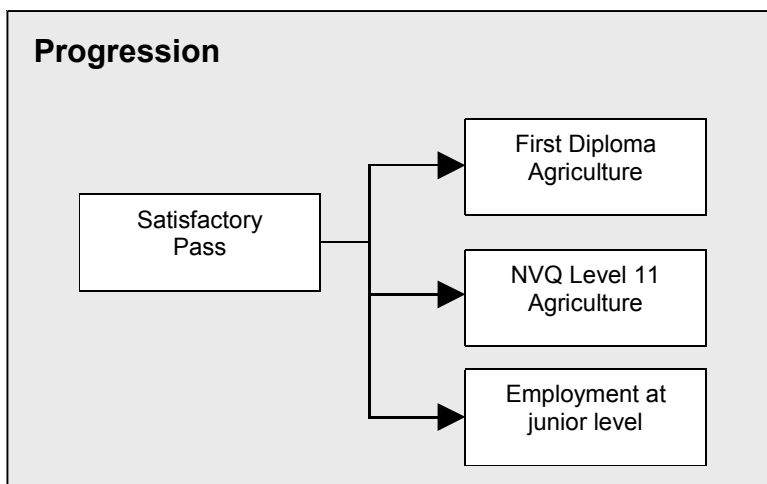

Participating institutions

Easton College

C&G NVQ Level 1

Land-based operations

Full-time: 1 year – 4 days a week in college

Part-time: 2 years - 2 days a week in college

Work experience: included

The College of West Anglia

C&G NVQ Level 1

General Agriculture

Part-time: 2 years – 1 day a week in college

Venue: Milton

First Diploma

This is a very practical course aimed at school leavers with some qualifications, or mature returners who wish to work within the agricultural industry with some supervision. The courses offer a general introduction to the subject, giving students a wide range of practical and theoretical skills. Students gain marks from practical classes, assignments/projects and short tests.

Entry Requirements:

Studied to GCSE level (Maths, English and Science) with at least 4 GCSEs at grades D-G, with 2 at grade D

Foundation in Land-related Industries

Foundation GNVQ in relevant subject

NVQ Level 1 Animal Care

Relevant work experience

Age:

16 years +

Must be:

Interested in subject area with evidence of academic ability

Areas of study may include

- Arable crop production
- Grassland/tractor driving
- Estate skills and workshop practice
- Farming and conservation
- Livestock production
- Agricultural machinery
- Health and safety

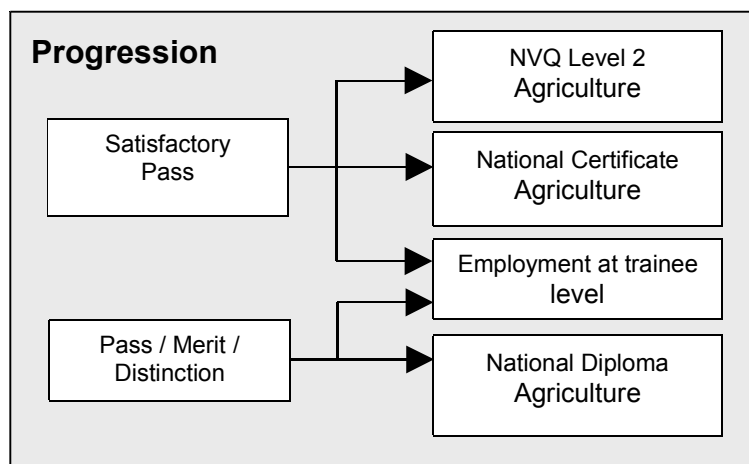

Participating institutions

Easton College

**Edexcel (BTEC)
First Diploma
Agriculture and
Farm
Mechanisation
Full-time:** 1 year – 4
days a week in
college
Work experience: 1
day a week

The College of West Anglia

**Edexcel (BTEC)
First Diploma
Agriculture
Full-time:** 1 year – 4
days a week in
college
Work experience: 1
day a week
Venue: Milton and
Wisbech

Writtle College

**Edexcel (BTEC)
First Diploma
Agriculture
Full-time:** 1 year – 4
days in college
Work experience: 1
day a week

Same course
available at
Shuttleworth

National Certificate

A one year full-time course that provides a highly practical introduction to the agricultural industry. Students will gain a broad base of agricultural knowledge such as fundamental farming principles and basic farm operations. Assessment is through end of unit assignments, written work and observation of practical sessions.

Entry Requirements:

Studied to GCSE level

First Diploma in Agriculture (Merit)

NVQ Level 2 (Pass)

GNVQ Intermediate in relevant subject (Pass)

Relevant experience for mature candidates

Age:

17 years +

Must be:

Dedicated to working within the industry with relevant experience

Areas of study may include

- Crop production
- Workshop skills
- Animal and plant science
- Estate maintenance
- Farm mechanisation
- Livestock production
- Records and accounts

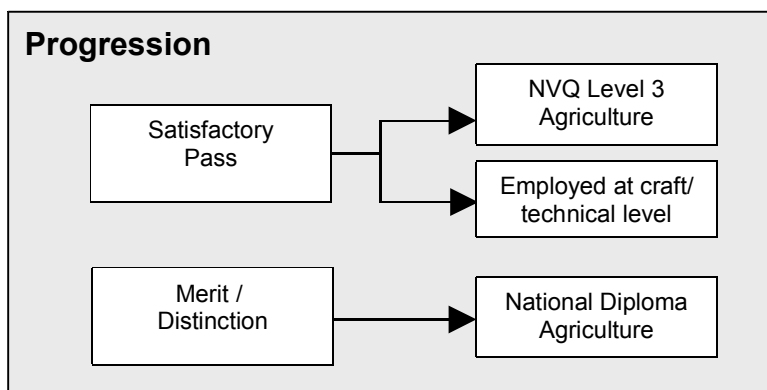

Participating institutions

Otley College

C&G National Certificate Agriculture

Full-time: 1 year – 4 days a week in college

Work experience: 1 day a week plus 5 weeks over Easter

Shuttleworth College

C&G National Certificate Agriculture

Full-time: 1 year – 5 days a week in college

Part-time: 2 years - students attend between November and March each year

NVQ Level 2

The NVQ Level 2 is aimed at students with some basic experience in agriculture who wish to gain a work-based qualification and expand their knowledge. Assessment takes place against the national standard by observation of practical tasks, assignments and building up a portfolio of evidence.

Entry Requirements:

Usually no formal qualifications are needed, however an appropriate working environment or voluntary placement is ideal

Age:

16 years +

Must be:

Dedicated to working within the industry with a basic level of secondary education

Areas of study may include

- Tractor handling
- Health and safety
- Livestock production
- Loading and unloading
- Management of resources
- Accommodation

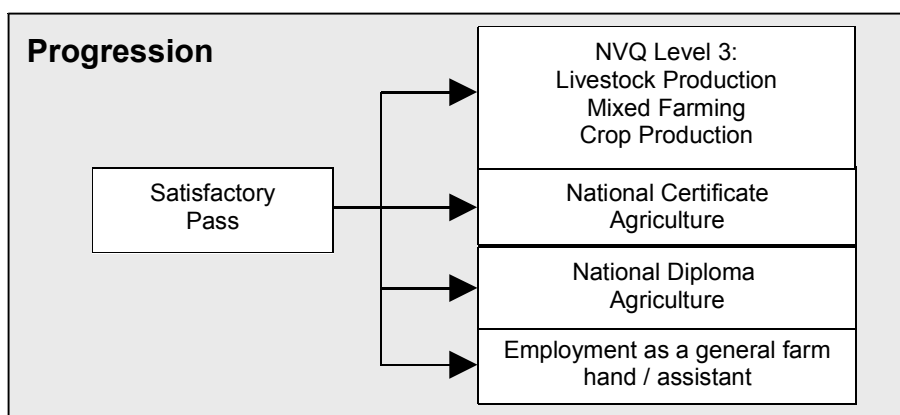

Participating institutions

<u>Easton College</u>	<u>Otley College</u>	<u>The College of West Anglia</u>	<u>Writtle College</u>
NVQ Level 2 in: Livestock (pigs, poultry, sheep, cattle)*, Mixed Farming*, Agricultural Crop Production* Part-time: 1 year	NVQ Level 2 in: Agricultural Crop Production* Part-time: 1 year	NVQ Level 2 in: Agriculture* Part-time: 2 years – 1 day a week in college. Venue: Milton	NVQ Level 2 Agriculture* Part-time: 2 years – 1 day a week in college

* Also available as an Apprenticeship

National Diploma

Aimed at school leavers, or mature students with previous experience, the course is a general introduction to agriculture, covering arable, livestock and general farming skills. Assessment takes place continuously through projects, practical work and assignments.

Entry Requirements:

4 GCSEs C+

First Diploma (Merit)

GNVQ Intermediate in relevant subject (Merit)

Mature entry

Students holding a national certificate in Agriculture may be admitted to a shortened programme

Age:

16 years +

Must be:

Interested in the agricultural industry

Areas of study may include

- Crop production (mechanised / arable)
- Estate skills
- Farm mechanisation
- Livestock production
- Soil, animal and plant science
- Conservation and wildlife management.

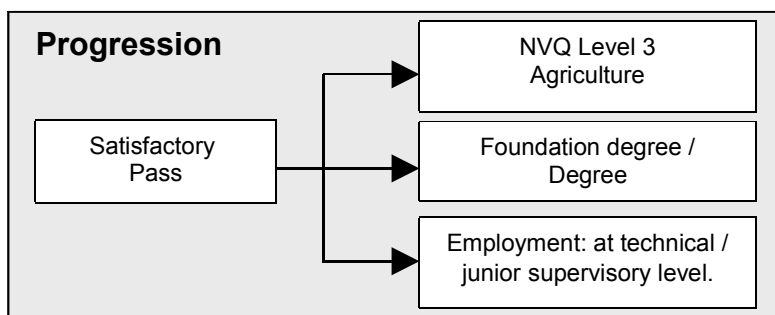

Participating institutions

<p>Easton College</p> <p>Edexcel (BTEC) National Diploma Agriculture and Farm Mechanisation Full-time: 2 years – 4 days a week in college Work experience: 1 day a week in college</p> <p>Edexcel (BTEC) National Diploma Land-based Technology Full-time: 2 years – 4 days a week in college Work experience: 1 day a week in college</p>	<p>The College of West Anglia</p> <p>Edexcel (BTEC) National Diploma Agriculture Full-time: 2 years – 5 days a week in college Work experience: 6 months Venue: Milton and Wisbech</p>	<p>Shuttleworth College</p> <p>Edexcel (BTEC) National Diploma Agriculture Full-time: 2 years – 5 day a week in college</p>	<p>Writtle College</p> <p>Edexcel (BTEC) National Diploma Agriculture Full-time: 3 years – 5 days a week in college Work experience: included</p>
---	--	---	---

NVQ Level 3

The NVQ Level 3 is aimed at students with some supervisory experience within the agricultural industry, who now want to gain a work-based qualification and expand their knowledge. Assessment takes place against the national standards by observation of practical tasks, assignments and building up a portfolio of evidence.

Entry Requirements:

No formal qualifications needed, however NVQ level 2 preferred

Age:

16 years +

Must be:

Employed within the industry at supervisory level

Areas of study may include

- Reproduction and breeding
- Nutrition and foodstuffs
- Housing and equipment
- Health and disease control
- Flock / herd management
- Recording systems
- Mechanical harvesting

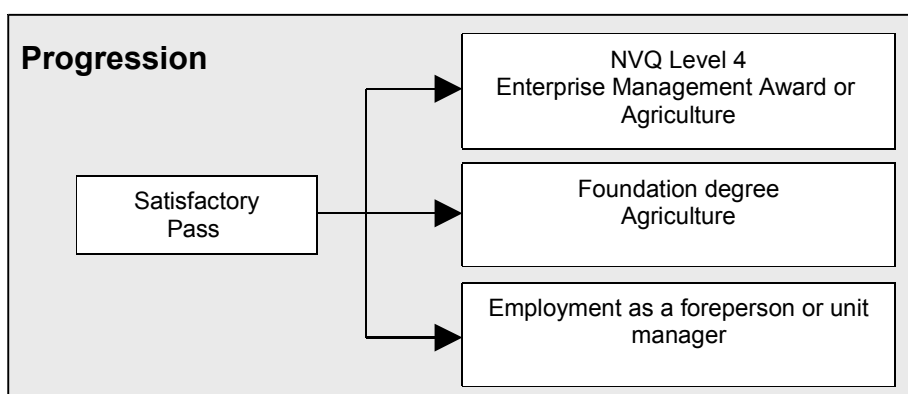

Participating institutions

Easton College

NVQ Level 3
Livestock (pig, poultry, sheep, cattle)*, Agricultural Crop Production*
Part-time: 1 year

Otley College

NVQ Level 3 in:
Agricultural Crop Production
Part-time: 1 year

Writtle College

NVQ Level 3
Agriculture
Part-time: 2 years
– 1 day a week in college

* Also available as an Apprenticeship

Choosing a Higher Education course in Agriculture

Foundation degree

Aims

The modules in this course offer students a sound agricultural husbandry, business and science background. There is an opportunity for students who successfully complete the course to progress onto the BSc (Hons) Agriculture or BSc Agriculture.

Entry Requirements:

40 UCAS tariff points

A maximum of 20 tariff points will be counted from Key Skills

Mature students with some formal qualifications but with experience of agriculture are encouraged to apply

Students with some formal qualifications i.e. Foundation diploma or NVQ and two years or more agriculture experience would also be considered

Age:

18 years +

Must be:

Interested in the subject area

Areas of study may include

- Crop and animal husbandry
- Business management
- Agricultural machinery
- Combinable and root crops
- Farm livestock production
- Habitat conservation with interpretation

Progression

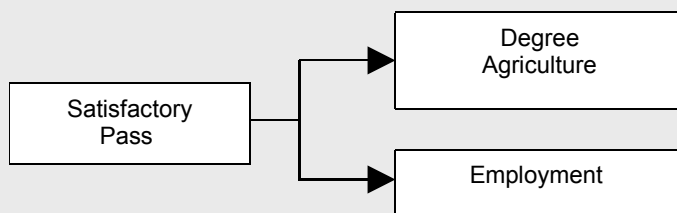

Participating institutions

Writtle College

FdSc Agriculture

UCAS Code: D403

Full-time: 2 years

This course can be studied on a part-time basis

Easton College

Currently HNC/HND programmes on offer but will change to Foundation degrees from Sept 2006, full and part-time

Honours degree

These degree level courses are aimed at developing vocational and academic skills in the agriculture sector. Students will be trained to apply scientific principles to their specialist area, while having the opportunity to gain broader skills in a variety of areas.

Entry Requirements:

A levels (Biology / Science preferred)

National Diploma

GNVQ Advanced Science (Merit / Distinction)

Relevant Foundation degree / HND (High Pass)

Relevant work experience / mature entry / interview

Age:

18 years +

Must be:

Interested in the subject area

Areas of study may include

- Soil mechanics for agriculture
- Product development and packaging
- Marketing and personnel
- Crop growth and protection
- Managing people

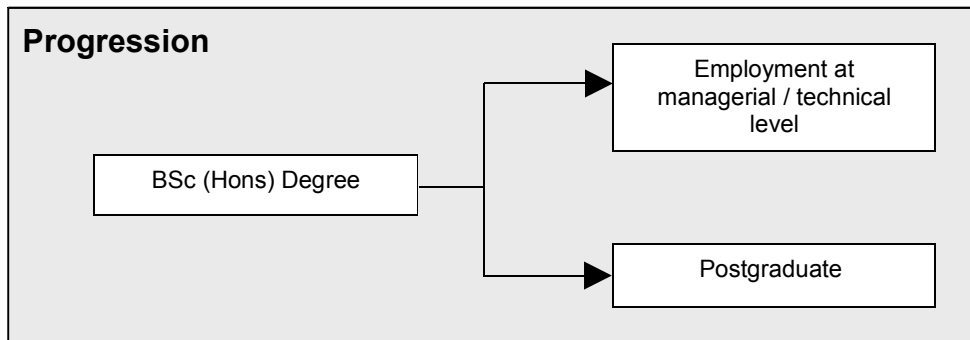

Participating institutions

Writtle College

BSc (Hons) Agriculture

UCAS Code: D401

Full-time: 3 years

**BSc (Hons) Agriculture with
Business Management**

UCAS Code: D4N2

Full-time: 3 years

**BSc (Hons) Agriculture and the
Environment**

UCAS Code: D4N2

Full-time: 3 years

Part-time study also available

Short and Leisure Courses

Poultry

Easton College

C&G First Certificate in Poultry

Edexcel (BTEC) First Diploma Poultry

NVQ Level 2 Poultry Production

Edexcel (BTEC) National Diploma Agriculture
(Poultry Management)

NVQ Level 3 Poultry Management

Food Production

Easton College

NVQ Level 1 and 2 Food and Drink

NVQ Level 1 and 2 Meat Processing

Otley College

NVQ Level 1, 2 and 3 Food and Drink
Manufacturing

NVQ Level 2 and 3 Meat and Poultry
Processing

The College of West Anglia

BSc (Hons) Food Science
UCAS code: D420

Gamekeeping

Otley College

NVQ Level 1 Agriculture (Gamekeeping)

Edexcel (BTEC) First Diploma
Gamekeeping

NVQ Level 2 Gamekeeping and Wildlife
Management

The College of West Anglia

NVQ Level 1 Gamekeeping
Venue: Wisbech

Edexcel (BTEC) National Diploma
Countryside Management (Gamekeeping)

Edexcel (BTEC) First Diploma Game
Management

Easton College

Edexcel (BTEC) First Diploma Countryside and Forestry (Gamekeeping)

Edexcel (BTEC) National Certificate Countryside Management (Gamekeeping)

Edexcel (BTEC) National Diploma Countryside Management (Gamekeeping)

Animal Studies

Introduction

The study of animals is becoming one of the most popular subjects within the land-related sector, mainly due to the large amount of media coverage about veterinary practices and animal shelters. A large number of potential students express an interest in working for the RSPCA or as a veterinary surgeon, not realising the extensive range of organisations and careers in existence. These include pet stores, the media, grooming parlours, kennels, zoos, animal sanctuaries, farms, the pet food industry, the Armed Forces, land-related colleges, research institutions, local councils and animal training organisations.

The Animal Science programmes are designed to train potential animal scientists, equipping them with both the knowledge and ability to work within the rapidly expanding animal industry.

The care and welfare of animals is a fast growing multi-million pound industry and there is a high demand for well trained, skilled employees at all levels. However, many of the jobs are at a junior level and tend to consist of long, unsociable hours and low wages. Staff work for the reward of being with animals.

Many of the animal organisations are charity-based or family run, therefore not able to offer full-time employment or wages, but can offer valuable work experience for students who are interested in a career within this sector. Potential students should show dedication, commitment and a love of animals, but also must be able to cope with such things as cleaning out animal accommodation, animal illness and death. An important part of animal care is also dealing with people and their pets, therefore customer care and relationship skills are important.

Studying animal science, management or care will give practical experience with a range of species from cats, dogs and rabbits to farm animals such as goats, cows and sheep, to exotics such as snakes and lizards. The courses cover all aspects of care, management and welfare of animals through a combination of theory, practical sessions and work experience. There are opportunities to study business management, develop IT skills and gain scientific knowledge.

Further Education

Qualification	Level	Course Title	Page
Foundation	Entry	<ul style="list-style-type: none"> Animal care Land-based industries 	26
NVQ Level 1	1	<ul style="list-style-type: none"> Animal care 	27
ABC Certificate	2 and 3	<ul style="list-style-type: none"> Small animal care Animal nursing assistant 	28
First Diploma	2	<ul style="list-style-type: none"> Animal care 	29
C&G National Certificate	2	<ul style="list-style-type: none"> Animal care 	30
NVQ Level 2	2	<ul style="list-style-type: none"> Animal care Dog grooming 	31
C&G Certificate	2	<ul style="list-style-type: none"> Dog grooming Animal care 	32
National Diploma / Certificate	3	<ul style="list-style-type: none"> Animal care Animal management 	33
NVQ Level 3	3	<ul style="list-style-type: none"> Animal welfare and management Animal care Dog grooming 	34

Higher Education

Qualification	Course Title	Page
Foundation degree (replacing HND/HNC)	<ul style="list-style-type: none"> FdSc Animal Management FdSc Animal Science 	35
Degree	<ul style="list-style-type: none"> BSc (Hons) Animal Behaviour BSc (Hons) Animal Management BSc (Hons) Animal Science 	36

Miscellaneous

Short and Leisure Courses	Page
<ul style="list-style-type: none"> Beekeeping, Honey Pollen Analysis, Queen Rearing, Adult Bee Diseases Introduction to Dog Grooming / Canine Studies Pet Store Management Care of Reptiles Sheep Husbandry Revision courses 	37

Linking subjects

An **animal studies** qualification can allow progression to other subject areas

Course
<ul style="list-style-type: none"> Conservation Equine studies Horticulture Land-related engineering Vet nursing

Choosing a Further Education Course in Animal Studies

Foundation Level

Aimed at those with little or no formal qualifications. This is an introduction to working with and caring for animals, while continuing to develop basic educational skills.

A high level of student support is given and students are instructed in communication, numeracy and life skills.

Entry Requirements:

No formal qualifications are needed

Age:

16 years +

Must be:

Interested in working with animals

Areas of study may include

- Feeding and watering animals
- Health and Safety
- Assisting with maintenance of animal accommodation
- Assisting in moving, restraining and exercising animals
- Communication

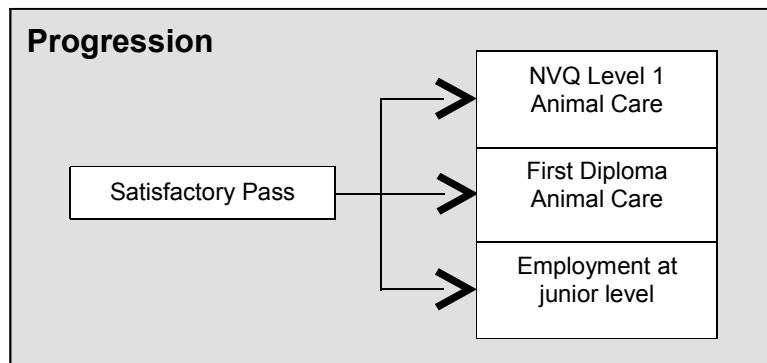

Participating institutions

Easton College

Edexcel Certificate Skills for Working Life
Full-time: 1 year – 4 days a week in college

Otley College

Foundation Programme – Animal Care – Access Animal Care
Full-time: 1 to 2 years
Work experience: 1 day a week plus 2 blocks of 1 week

The College of West Anglia

Foundation Course – Animal Care
Full-time: 1 year – 4 days a week in college
Work experience: In animal care unit
Venue: Milton or Wisbech

NVQ Level 1

Normally lasting one year, the NVQ Level 1 is designed as a basic introduction to working with and caring for animals. This is a work-based qualification and is assessed by observation of practical activities and by building up a portfolio of evidence.

Entry Requirements:

No formal qualifications are required

Age:

16 years +

Must be:

Interested in working with animals with a basic level of secondary education

Areas of study may include

- Maintaining the provision of food and water to animals
- Assisting in maintaining animal accommodation
- Maintaining animal health and welfare
- Assisting in the moving, exercising and restraining of animals
- Maintaining personal hygiene, health and safety
- Dealing with customers and liaising with colleagues
- Communication

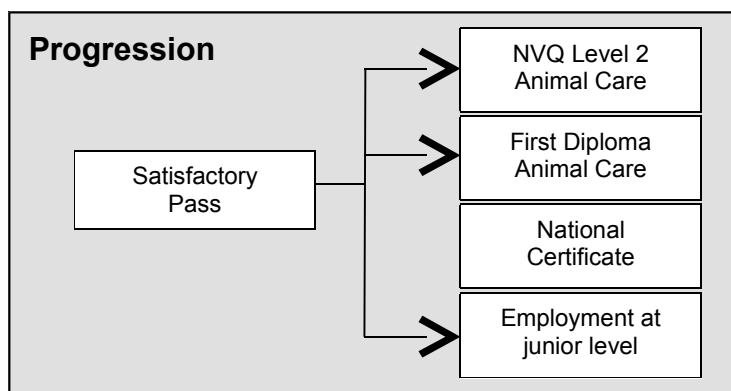

Participating institutions

Easton College

**C&G NVQ Level 1
Land-based
Operations**

Full-time: 1 year – 4
days a week in college

Part-time: 2 years – 2
days a week in college

Work experience:
included

The College of West Anglia

**NVQ Level 1 Animal
Care**

Full-time: 1 Year – 4
days a week in
college.

Part-time: 1 year – 1
day a week in college

Venue: Milton or
Wisbech

ABC Certificate

An introduction for those with little previous experience with animals who would like a career in the animal care industry.

Entry Requirements:

2 GCSEs at grade D or above (including Science, English and Maths)

Mature entry

Age:

16 years +

Must be:

Interested in working with animals

Areas of study may include

- Anatomy and physiology
- Nutrition
- Breeding
- Health
- First Aid
- Reception
- Kennel and cattery management
- Pet store management
- Genetics and grooming

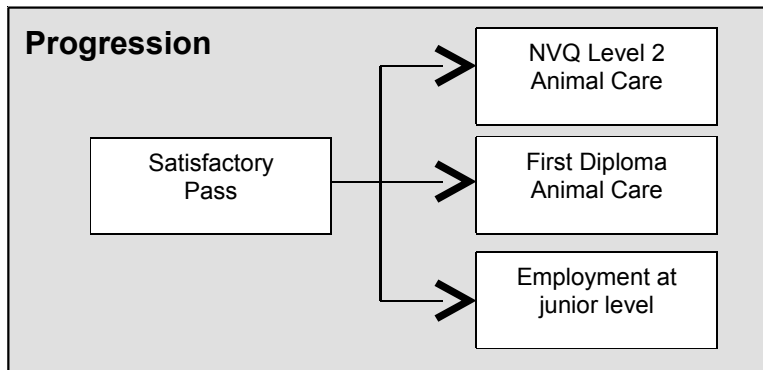

Participating institutions

Writtle College

ABC Certificate Small Animal Care

Part-time: 1 year – 1 day a week in college

ABC Certificate Animal Nursing Assistant

Part-time: 1 year – 1 day a week in college

First Diploma

Aimed at school leavers with some qualifications, or mature returners who wish to work within the animal care industry with a certain degree of supervision. Work places include kennels, rescue centres, grooming parlours and pet shops. The course is assessed by practical exercises and assignments throughout the year.

Entry Requirements:

Studied to GCSE Level (including Maths and English grade C or above)

Foundation in Animal Care / Land-Based Industries (Pass)

Foundation GNVQ in relevant area (Pass)

NVQ Level 1 Animal Care (Pass)

Relevant work experience

Age:

16 years +

Must be:

Interested in animals

Areas of study may include

- Housing
- Health and disease
- Nutrition / First Aid
- Animal care
- Administration and personal skills
- Introduction to veterinary nursing
- Introduction to dog grooming

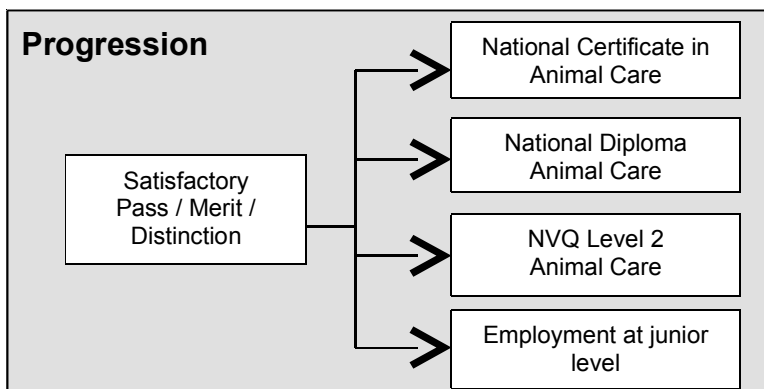

Participating institutions

Easton College

**Edexcel (BTEC)
First Diploma in
Animal Care**
Full-time: 1 year –
4 days a week in
college
Work experience:
1 day a week

Otley College

**Edexcel (BTEC)
First Diploma
Animal Care**
Full-time: 1 year

Writtle College

**Edexcel (BTEC)
First Diploma
Animal Care**
Full-time: 1 year – 4
days a week in
college
Work experience:
1 day a week

The College of West Anglia

**Edexcel (BTEC)
First Diploma
Animal Care**
Full-time: 1 year –
4 days a week in
college
Work experience:
1 day a week or one
block of 5 weeks
Venue: Milton or
Wisbech

Shuttleworth College

Edexcel (BTEC) First Diploma Animal Care
Full-time: 1 year – 4 days a week in college
Work experience: 1 day a week

City & Guilds National Certificate

A one year full-time course that provides a highly practical introduction to the animal care industry. Students are introduced to a wide range of animal-related subjects and undertake a number of assignments and major projects.

Entry Requirements:

Studied to GCSE level (including Maths and English grade C or above)

First Diploma in Animal Care (Pass)

GNVQ Intermediate in relevant subject

Mature entry

Age:

16 years +

Must be:

A dedication to working with animals with a year's relevant experience within the industry

Areas of study may include

- Customer care and retailing
- First Aid and animal care
- Animal care and welfare / applied science
- Records and supervision
- Animal husbandry / small mammals

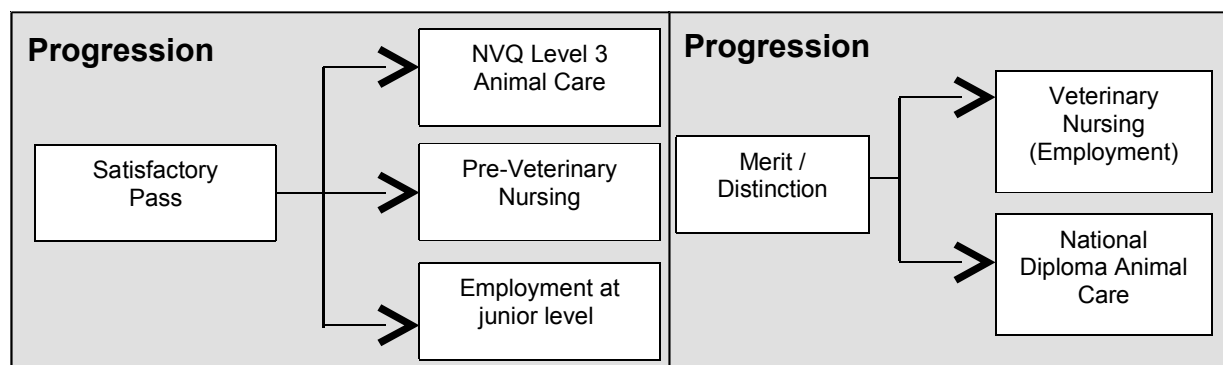

Participating institutions

<p><u>Otley College</u></p> <p>C&G National Certificate Animal Care Full-time: 1 year</p>	<p><u>Shuttleworth College</u></p> <p>C&G National Certificate Animal Care Full-time: 1 year – 5 days a week in college Work experience: 1 day a week</p>	<p><u>Writtle College</u></p> <p>C&G National Certificate Animal Care Full-time: 1 year – 1 day a week in college Work experience: 1 day a week</p>
---	---	---

NVQ Level 2

The NVQ Level 2 is aimed at students with some basic experience in animal care who want to gain a work-based qualification and expand their industrial knowledge. Students will usually be employed within the industry or take part in relevant voluntary work. Assessment takes place against the national standards by observation of practical tasks, assignments and building up a portfolio of evidence.

Entry Requirements:

No formal qualifications are required, however an appropriate working environment or voluntary placement is ideal

Age:

16 years +

Must be:

Dedicated to working with animals with a basic level of secondary education

Areas of study may include

- Safe working practices
- Animal health and well being
- Nutrition and housing
- Recording information
- Loading and transporting animals
- Assisting with veterinary treatments
- Dealing with customers

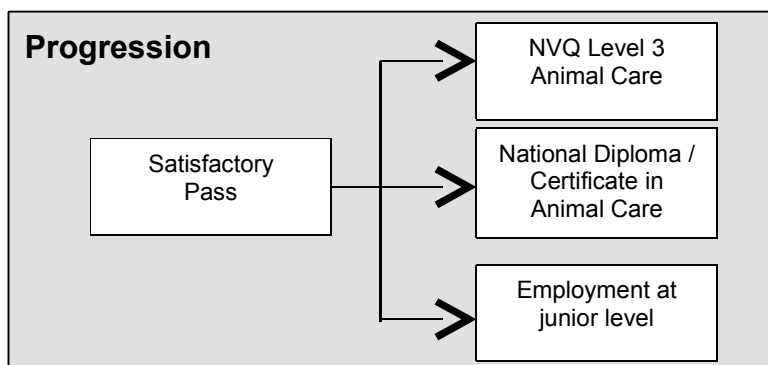

Participating institutions

<p>Otley College</p> <p>NVQ Level 2 Animal Care Apprenticeship Work experience: Students need relevant employment or a suitable placement</p>	<p>The College of West Anglia</p> <p>NVQ Level 2 Animal Care * Part-time: Programme individually negotiated to suit student needs</p> <p>NVQ Level 2 and Level 3 Dog Grooming Part-time: 1 year Venue: Wisbech or Milton</p>	<p>Easton College</p> <p>NVQ Level 2 Animal Care * Part-time: 1 year – 1 day a week in college</p> <p>Shuttleworth College</p> <p>NVQ Level 2 Animal Care/Dog Grooming* Part-time: 1 year – 1 day a week</p>	<p>Writtle College</p> <p>NVQ Level 2 Animal Care * Full-time: 1 year + - on an outreach basis Work experience: employment within an animal-related business</p>
---	--	--	--

** Also available as an Apprenticeship*

City and Guilds Certificate

The dog grooming industry has “taken off” in the last few years. Courses range from introductory taster sessions to more advanced courses. The latter are aimed at candidates with some underpinning knowledge, who desire to groom and trim dogs to a highly professional standard. Such courses are ideal for those looking to start their own business in dog grooming.

The City and Guilds 7750 examination comprises of a two hour written paper and a one-day practical examination. There are three levels - Foundation, Intermediate and Advanced, with each taking a year to complete.

Entry Requirements:

No formal qualifications are required, but previous experience is desirable

Age:

16 years +

Must be:

Interested in the subject with a liking for dogs

Areas of study may include

- Bathing and conditioning the coat
- Trimming / drying and styling
- Aftercare, safety and hygiene
- Parlour management
- Skin complaints / worms / parasites
- RSPCA / health and welfare

Participating institutions

Easton College

**Units of C&G NVQ
Level 2 Dog
Grooming**
Part-time: 1 year – 1
day a week in college

Shuttleworth College

C&G Dog Grooming
Part-time: 3 years – 1
day a week in college

**C&G Certificate
Animal Care**
Full-time: 1 year

Writtle College

**C&G Dog
Grooming**
Part-time: 1 year –
1 day a week in
college

National Diploma / Certificate

A one or two year course for school leavers with a number of GCSEs or for mature returners wanting a career in the animal care industry at a supervisory level.

Entry Requirements:

4 GCSEs C+ (English, Maths, Science)
 First Diploma Animal Care (Merit/Distinction)
 GNVQ Intermediate in a relevant subject (Pass)
 Mature entry/relevant work experience

Age:

16 years +

Must be:

Interested in working with animals

Areas of study may include

- Animal science / nutrition
- Anatomy and physiology
- Animal health and welfare
- Ecology and the environment
- Supervisory studies
- Behaviour and handling
- Animal breeding and genetics
- The working environment
- Animals and society
- Aquatics / exotics
- Pet shop management
- Farm livestock/ dog training
- Wildlife rehabilitation
- Kennel and cattery management

Progression

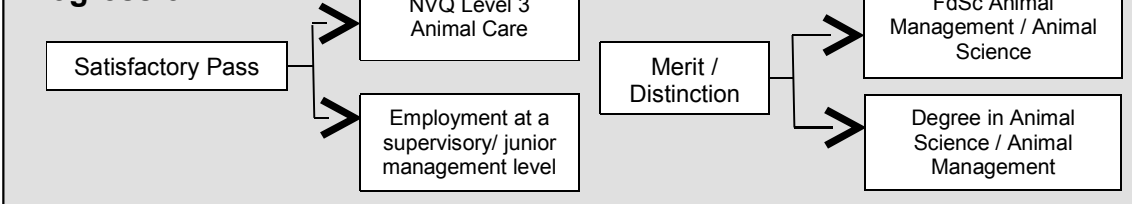

Participating institutions

Easton College

**Edexcel (BTEC)
 National Diploma
 Animal
 Management**
Full-time: 2 years –
 4 days a week in
 college
Work experience: 1
 day a week

Otley College

**Edexcel (BTEC)
 National Diploma
 Animal Management**
Full-time: 2 years

The College of West Anglia

**Edexcel (BTEC)
 National Diploma
 Animal
 Management**
Full-time: 2 years
 – 5 days a week in
 college
Work experience:
 6 weeks a year

Writtle College

**Edexcel (BTEC)
 National Diploma
 Animal
 Management**
Full-time: 2 years –
 4 days a week in
 college
Part-time: Associate
 Student Learning
 Programme
Work experience:
 1 day a week

Shuttleworth College

**Edexcel (BTEC) National Diploma Animal
 Care**
Full-time: 2 years – 4 days a week
Work experience: 1 day a week

**C&G Advanced
 National Certificate
 Animal Care**
Full-time: 1 year – 3
 days a week

NVQ Level 3

The NVQ Level 3 is aimed at those already employed within the animal care industry at a supervisory level, who wish to gain a recognised work-based qualification. This is a part-time course assessed by observation of practical activities and a portfolio of evidence.

Entry Requirements:

NVQ Level 2 (pass)
National Certificate / Diploma (Pass) and in appropriate employment
Relevant experience

Age:

16 years +

Must be:

In a supervisor role within the animal care industry

Areas of study may include

- Safe working practices
- Animal health and well being
- Diets and accommodation
- Recording information
- Loading and transporting animals
- Assisting with veterinary treatment
- Dealing with customers

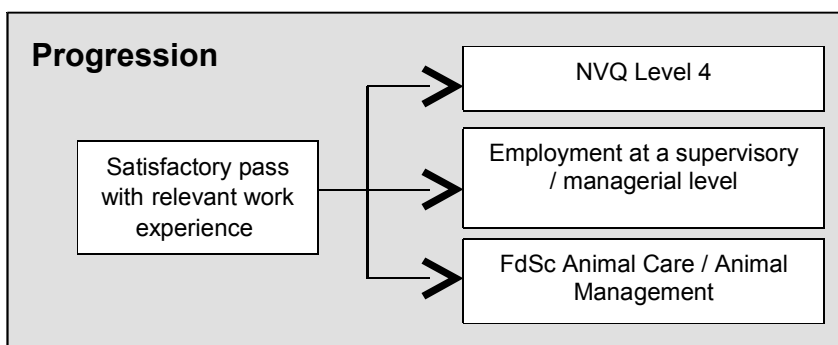

Participating institutions

<p><u>Easton College</u></p> <p>NVQ Level 3 Animal Care* NVQ Level 3 Animal Management* Part-time: 1 year – students are supported through regular evening / daytime tutorials</p>	<p><u>Otley College</u></p> <p>NVQ Level 3 Animal Care Part-time: 1 year + – programme individually structured to suit as work-based training</p> <p>National Award Animal Management Full-time: 1 year Part-time: 2 years</p>	<p><u>The College of West Anglia</u></p> <p>NVQ Level 3 Animal Welfare and Management* Part-time: 1 year + – 1 day a week in college</p>	<p><u>Shuttleworth College</u></p> <p>NVQ Level 3 Animal Care / Dog Grooming* Part-time: 1 year + – 1 day a week in college</p>
--	--	---	--

Choosing a Higher Education Course in Animal Studies

Foundation degree

These courses are aimed at developing vocational and academic skills in the animal science and management sector. Students will be trained to apply scientific principles to their specialist area, while having the opportunity to gain broader skills in a variety of areas.

Entry Requirements:

60 UCAS tariff points

A maximum of 20 tariff points will be counted from Key Skills

Mature students with some formal qualifications and two years or more relevant experience will also be considered.

Age:

18 years +

Must be:

Interested in the subject with a liking for animals

Areas of study may include

- The animal's environment
- Animal nutrition
- Biological processes
- Applied companion
- Animal management
- Anatomy and physiology
- Animal management

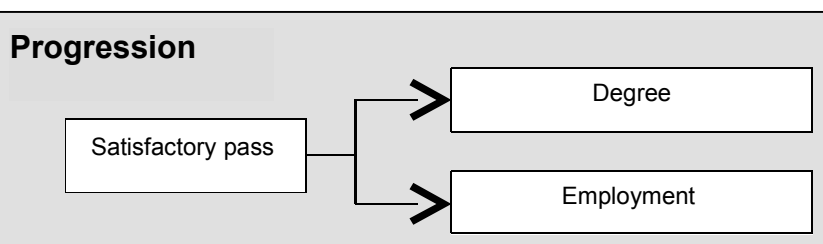

Participating institutions

Otley College

FdSc Animal Management

Full-time: 2 years -
1 day a week at college

Writtle College

FdSc Animal Management

UCAS Code: D291
Full-time: 2 years
Part-time: 4 years

FdSc Animal Science

UCAS Code: D300
Full-time: 2 years
Part-time: 4 years

Shuttleworth College

FdSc Animal Management

UCAS Code: D391
Full-time: 2 years
Part-time: 4 years

Easton College

Currently HNC/HND programmes on offer but will change to Foundation degrees from Sept 2006, full and part-time.

Honours degree

These degree level courses are aimed at developing vocational and academic skills in the animal science and management sector. Students will be trained to apply scientific principles to their specialist area, while having the opportunity to gain broader skills in a variety of areas.

Entry Requirements:

A levels (Biology / Science preferred)
National Diploma (MMP)
GNVQ Advanced Science (Merit / Distinction)
Relevant Foundation degree or HND (High Pass)
Relevant work experience / mature entry

Age:

18 years +

Must be:

Interested in animal science / management

Areas of study may include

- Animal behaviour
- Reproduction and genetics
- Anatomy and physiology
- The animal's environment
- Animal ecology
- Wildlife in a changing environment
- Alternative companion animals

Progression

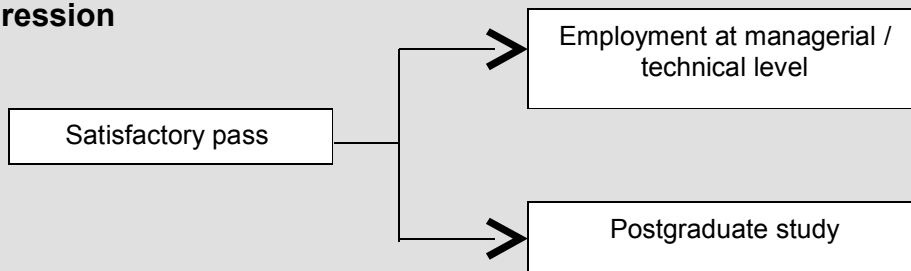

Participating institutions

Writtle College

BSc (Hons) Animal Science
UCAS Code: D321
Full-time: 3 years

BSc (Hons) Animal Management
UCAS Code: D291
Full-time: 3 years

Part-time study also available

Short Courses

A number of colleges run short courses in animal care ranging from pet behaviour to dog training and microchip implanting to pet bereavement. These are stand-alone courses, which can lead onto further qualifications.

Please note that these courses may be subject to change at any time.

Formal qualifications are not usually required, though some of the more advanced courses may expect students to have some previous practical studies.

Participating institutions

Easton College

Introduction to Beekeeping

Part-time: 10 weeks – 1 evening a week in college

Practical Beekeeping

Part-time: 8 weeks - 1 evening a week in college

Beekeeping 2

Part-time: 10 weeks – 1 evening a week in college

Other courses include:

Honey Pollen Analysis

Queen Rearing

Adult Bee Diseases

Otley College

Beekeeping

Part-time: 8 to 10 weeks - evenings

Shuttleworth College

C&G Canine Studies

Part-time: 1 year – 1 day a week in college

The Pet Care Trust Certificate in Pet Store Management

Part-time: 1 year – block release aimed at pet store owners, staff and trainees to develop their knowledge and skills

Writtle College

Courses include:

Dog Grooming

Care of Reptiles

Sheep Husbandry

Anatomy and Physiology Revision Course

Laboratory Revision Course

Canine Studies

Part time: 1 year – 1 day a week in college

Business

Introduction

Today's managers need to keep one step ahead of the rapid changes in the business environment. The wide range of skills possessed by a well-trained manager are in high demand across all commercial industries and service organisations. Successful managers are equipped with communication skills, a good grasp of financial planning techniques, the ability to manage change and a sound understanding of marketing and product development. A career in business management can be extremely lucrative for those with a solid educational background.

There are over 2.9 million people engaged in business in this country but fewer than 20% have a nationally recognised qualification. These courses will provide students with the opportunity to stand out from the crowd.

Further Education

Qualification	Level	Course Title	Page
C&G Certificate	1, 2 & 3	<ul style="list-style-type: none"> • Retailing (subject to approval) • Business Administration • Information Technology 	40
First Diploma	2	<ul style="list-style-type: none"> • Business 	41
NVQ Level 3	3	<ul style="list-style-type: none"> • Management 	42
National Diploma / Certificate	3	<ul style="list-style-type: none"> • Business or Retail Management 	43

Higher Education

Qualification	Course Title	Page
Foundation degree (replacing HND/ HNC)	<ul style="list-style-type: none"> • FdA Business Management 	44
Degree	<ul style="list-style-type: none"> • BSc (Hons) Marketing and Supply Chain Management • BA (Hons) Business Management 	45

Miscellaneous

Short and Leisure Courses	Page
<ul style="list-style-type: none"> • First Aid at Work • First Aid at Work Refresher • Emergency First Aid • Health and Safety General and Risk Assessment 	46

Linking Subjects

A **business management** course can allow progression into other subject area

Course
<ul style="list-style-type: none"> • Leisure Management • Marketing • HR Management

Choosing a Further Education Course in Business Management

C & G Certificate

To provide basic knowledge and skills required in business management. The programme will also look at the past influences on business management. Assessment is by continuous assessment, end of module tests and practical assessments.

Entry Requirements:

No formal entry requirements

Age:

16 years +

Must be:

Interested in subject area

Areas of study may include

- Pricing and display
- Product knowledge
- Handling customers
- Website design
- Digital photography
- IT principles
- Presentation graphics

Progression

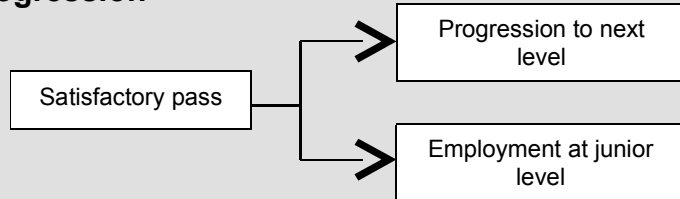

Participating institutions

Otley College

**C&G Levels 1 & 2
Information
Technology**
Full-time: 1 year – 3
days a week in college

**C&G Levels 1 & 2
E-Quals Information
Technology**
Part-time: 120 hours,
2x2 hours per week

**C&G Levels 1 & 2
Business
Administration**
Full-time: 1 year – 3
days a week in college

Writtle College

C&G Retailing Level 2
Full-time: 1 year – 1
evening a week

C&G Retailing Level 3
Full-time: 1 year – 1
day a week in college
Part-time: 2 years – 1
evening a week

First Diploma

This is a very practical course aimed at school leavers with some qualifications, or mature returners who wish to work within the business management area with some supervision. The course offers a general introduction to the subject, giving students a wide range of practical and theoretical skills. Students gain marks from practical classes, assignments/projects and short tests.

Entry Requirements:

Studied to GCSE level (Maths, English and Science)
Foundation in Land-related Industries
Foundation GNVQ in relevant subject
NVQ Level 1 Animal Care
Relevant work experience

Age:

16 years +

Must be:

Interested in subject area with evidence of academic ability

Areas of study may include

- Applied business
- Accounts
- Law
- Maths and English

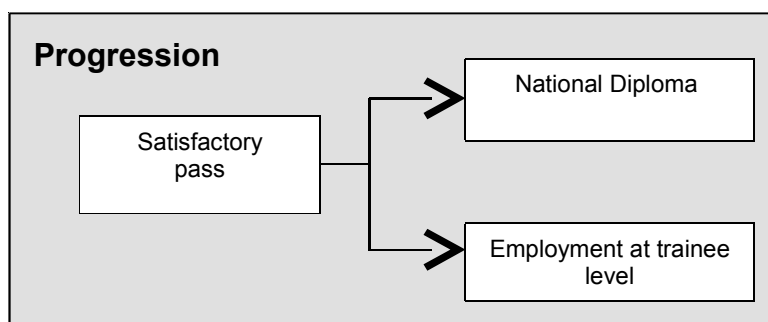

Participating institutions

The College of West Anglia

**BTEC First Diploma
Business**

Full-time: 1 year

Venue: King's Lynn

NVQ Level 3

The NVQ Level 3 is aimed at students with some supervisory experience within the business environment, who now want to gain a work-based qualification and expand their knowledge. Assessment takes place against the national standard by observation of practical tasks, assignments and building up a portfolio of evidence.

Entry Requirements:

No formal qualifications needed, however NVQ level 2 preferred

Age:

16 years +

Must be:

Employed within the industry at supervisory level

Areas of study may include

- Managing yourselves and others
- Creating effective working relationships
- Managing information for action
- Support for efficient use of resources
- Maintain activities to meet requirements

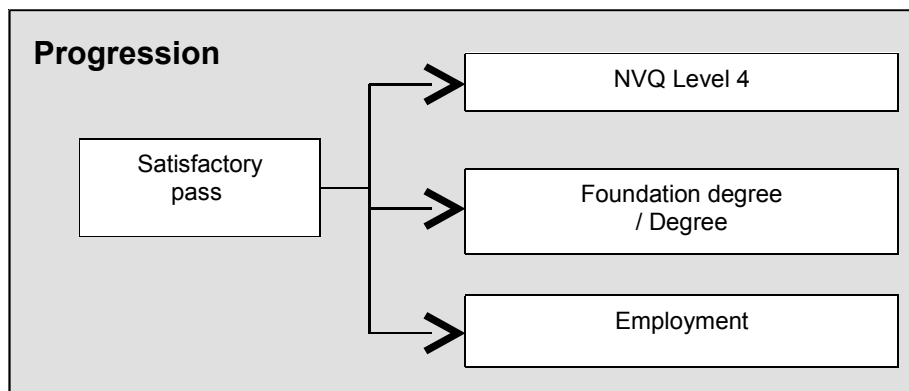

Participating institutions

Writtle College

NVQ Level 3 Management

Part-time: 2 years – 1 day a week in college

National Diploma / Certificate

This course is designed for those who want to develop a detailed understanding of business. It will develop skills, knowledge and understanding for those who aspire to trainee management job roles or to gain places in higher education.

Entry Requirements:

4 GCSEs C+ (English, Maths, Science)
GNVQ Intermediate in a relevant subject (Pass)
Mature entry/relevant work experience

Age:

16 years +

Must be:

Interested in subject area

Areas of study may include

- Business studies
- Law
- Government and politics
- Economics
- Accounting

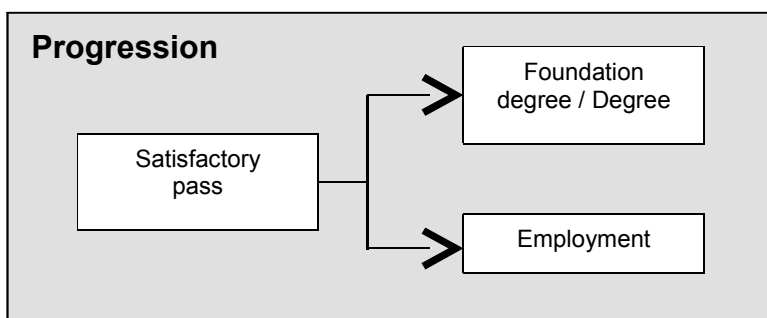

Participating institutions

Easton College

**National Certificate
Business**
Full-time: 2 years

The College of West Anglia

**BTEC National
Diploma Business
or Retail
Management**
Full-time: 2 years
Venue: King's Lynn

Choosing a Higher Education Course in Business Management

Foundation degree

This course is aimed at developing vocational and academic skills in the business sector. Students will be trained to apply principles to their specialist area, while having the opportunity to gain broader skills in a variety of areas.

Entry Requirements:

60 UCAS tariff points

A maximum of 20 tariff points will be counted from Key Skills

Mature students with some formal qualifications and two years or more relevant experience will also be considered.

Age:

18 years +

Must be:

Interested in the subject

Areas of study may include

- Business environment
- Business management
- Legal context
- Marketing
- Managing people
- Event management
- Information systems

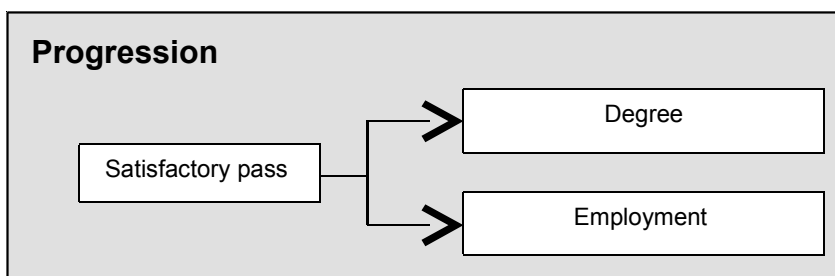

Participating institutions

Writtle College

FdA Business Management

UCAS Code: N202

Full-time: 2 years

This course can be studied on a part-time basis

Honours degree

These degree level courses are aimed at developing vocational and academic skills in the business sector. Students will be trained to apply business principles to their specialist area, while having the opportunity to gain broader skills in a variety of areas.

Entry Requirements:

A Levels

National Diploma

GNVQ (Merit / Distinction)

Relevant Foundation degree or HND (High Pass)

Relevant work experience / mature entry

Age:

18 years +

Must be:

Interested in business management

Areas of study may include

- Role and function of management
- Marketing
- Managing people
- Strategic management
- Business administration
- Consumer behaviour

Progression

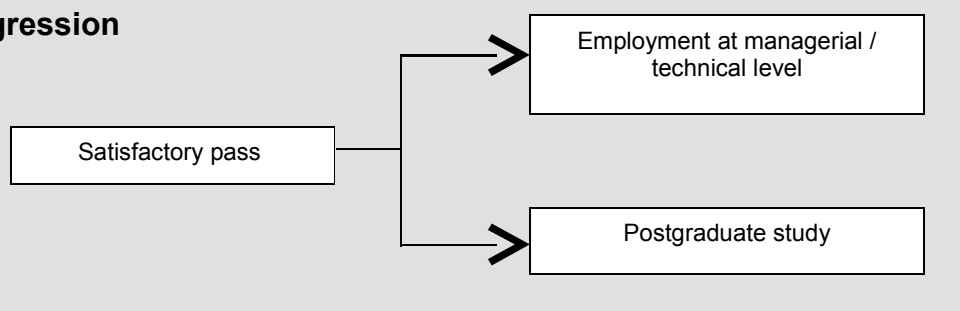

Participating institutions

The College of West Anglia

BSc (Hons) Business Management
UCAS Code: N250
Full-time: 3 years

Writtle College

BSc (Hons) Marketing and Supply Chain Management
UCAS Code: N500
Full-time: 3 years

BA (Hons) Business Management
UCAS Code: N200
Full-time: 3 years

Part-time study also available

Short Courses

A number of colleges run short courses in business management. These are stand-alone courses, which can lead on to further qualifications.

Please note that these courses may be subject to change at any time.

Formal qualifications are not usually required, though some of the more advanced courses may expect students to have some previous practical studies.

Participating institutions

Writtle College

First Aid at Work
First Aid at Work Refresher
Emergency First Aid
Health and Safety – General
Health and Safety – Risk Assessment

Easton College

First Aid at Work
First Aid at Work Refresher
Emergency First Aid
Health and Safety – Risk Assessment
Institute of Leadership and Management Team Leader Certificate
Institute of Leadership and Management First Line Manager Certificate
OCR Levels 1, 2 and 3 Certificate for IT Users

Countryside Management and Environmental Conservation

Introduction

Environmental conservation and countryside management are broad terms for the preservation and protection of habitats and landscapes on a local to international scale, and also cover the management of land use for industry, tourism, sport and recreation. This is a highly diverse subject, linked to many other disciplines and covering such areas as estate management, archaeology, waste management, building conservation, wildlife conservation, tourism, planning and ecology.

A large number of work opportunities have opened up within these areas in the last few years and this is reflected in the growing number of courses now offered by colleges and universities. However, a large part of the workforce is voluntary and there is growing competition for jobs with a wage, especially for the higher paid opportunities. Companies are looking for employees with qualifications and experience. It is therefore vital for potential employees to have as much experience as possible. This may be gained by joining an organisation as a volunteer, through work experience while studying, going abroad with such organisations as VSO or starting at the bottom of the ladder with a low-paid job and working upwards.

Colleges and employers look for people with commitment and enthusiasm. Students will need to be flexible and able to work alone, to carry responsibility, and make important decisions based on evidence and research. Some careers require a lot of contact with the public, so good communication skills are a necessity. A high level of computer literacy is required for a career in management or research. Courses reflect the needs of the industry, providing students with skills in management, IT and scientific principles as well as hands-on experience in a variety of countryside settings and habitats.

There are many different careers available, both out in the environment and/or office based. Examples of such positions include: countryside ranger, lecturer, environmental researcher or consultant, pest controller, project officer or manager, zoo assistant, waterways operative, public rights of way officer, ground worker or a nature reserve warden.

Suitable jobs are more likely to become available if employees are prepared to move around the country or even internationally. Some opportunities may be on a short term contract only, as projects tend to be dedicated by funding and circumstances. The pay can be low and hours of work irregular, such as at weekends, evenings and on Bank Holidays. The job can involve a large amount of variety. Employees may be on a field trip one day, in all sorts of working conditions, then be giving a presentation in the office the next. There are opportunities to become highly specialised, but many positions require a broad knowledge across other disciplines.

Further Education

Qualification	Level	Course Title	Page
Foundation	Entry	<ul style="list-style-type: none"> • Conservation • Skills for Working Life • Land-based operations 	49
ABC Certificate	2 and 3	<ul style="list-style-type: none"> • Field Archaeology 	50
First Diploma	2	<ul style="list-style-type: none"> • Countryside and Forestry • Countryside and environment • Countryside Studies • Rural Studies • Wildlife and Countryside Care 	51
City and Guilds	2	<ul style="list-style-type: none"> • Arboriculture 	52
NVQ Level 2	2	<ul style="list-style-type: none"> • Environmental Conservation • Forestry and Woodland Management • Gamekeeping 	53
National Certificate	2 and 3	<ul style="list-style-type: none"> • Environmental Conservation 	54
National Diploma	3	<ul style="list-style-type: none"> • Countryside Management • Forestry and Arboriculture • Countryside management • Countryside management (woodland management) • Wildlife and Countryside Management 	55
NVQ Level 3	3	<ul style="list-style-type: none"> • Environmental Conservation • Gamekeeping 	56

Higher Education

Qualification	Course Title	Page
Foundation degree (replacing HND/HNC)	<ul style="list-style-type: none"> • FdSc Conservation and Environment • FdSc Species and ecosystems conservation 	57
Degree	<ul style="list-style-type: none"> • BSc (Hons) Rural Resource Management • BSc (Hons) Conservation and Environment • BSc (Hons) Wildlife Management • BA (Hons) Outdoor Recreation and Conservation (subject to validation) 	58

Miscellaneous

Short and Leisure Courses	Page
<ul style="list-style-type: none"> • Conservation Studies 	59

Linking subjects

A **countryside management or environment conservation** course can allow progression onto other related subject as

Course
<ul style="list-style-type: none"> • Agriculture • Animal Studies • Horticulture • Land-related Engineering

Choosing a Further Education Course in Countryside Management and Environmental Conservation

Foundation Level

Aimed at those with little or no formal qualifications. This is an introduction to working within the conservation and countryside management sector, while continuing to develop basic educational skills.

A high level of student support is given and students are instructed in communication, numeracy and life skills.

Entry Requirements:

No formal qualifications are needed but evidence of basic numeracy and literacy will be required

Age:

16 years +

Must be:

Interested in conservation

Areas of study may include

- Foundation conservation
- Practical environmental skills
- Personal development
- Enterprise or community project
- Literacy and numeracy skills

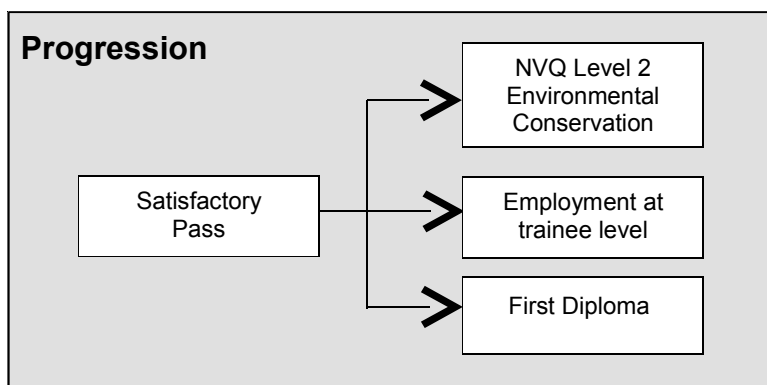

Participating institutions

Otley College

Foundation Conservation

Full-time: 1 year – 5 days a week in college

Work experience: Included

Easton College

Edexcel Certificate Skills for Working Life

Full-time: 1 year – 4 days a week in college

NVQ Level 1 Land-based Operations

Full-time: 1 year – 4 days a week in college

Work experience: Included

ABC Certificate

This course will provide you with the practical skills and techniques required for field archaeology.

Entry Requirements:

2 GCSEs at grade D or above (including Science, English and Maths)

Mature students

Age:

16 years +

Must be:

Interested in the subject

Areas of study may include

- Field surveying
- Excavation techniques
- Site recording
- Archiving
- Forensic archaeology

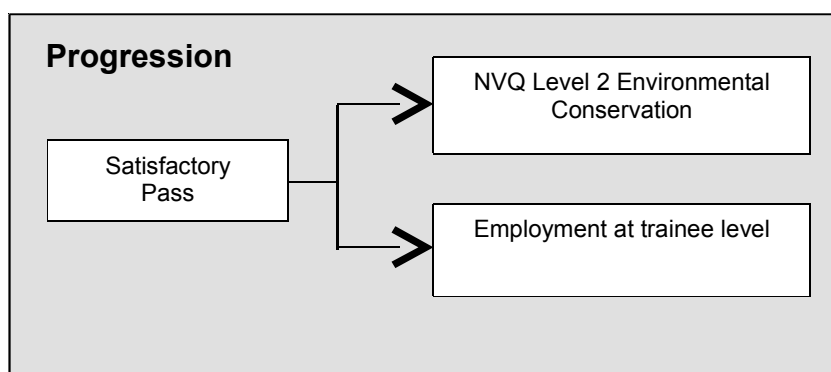

Participating institutions

Writtle College

ABC Field
Archaeology
Level 2 and 3
Part-time: 1
year

First Diploma

Aimed at school leavers with some qualifications, or mature returners who wish to work within countryside management / environmental conservation with some supervision. The course is assessed by practical exercises and assignments throughout the year.

Entry Requirements:

Studied to GCSE Level
Foundation in Land-Based Industries
Previous relevant experience

Age:

16 years +

Must be:

Interested in subject area

Areas of study may include

- Conservation
- Habitat management
- Mechanisation in the countryside
- Science and technology
- Health and safety

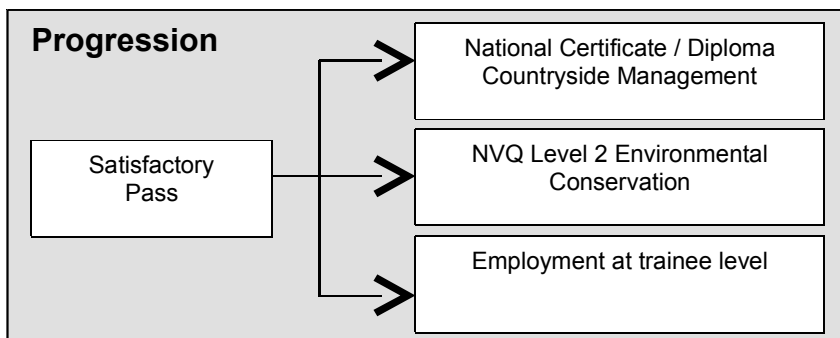

Participating institutions

<p><u>Easton College</u></p> <p>Edexcel (BTEC) First Diploma in Rural Studies Full-time: 1 year – 4 days a week in college Work experience: 1 day a week</p> <p>Edexcel (BTEC) First Diploma Countryside and Environment Full-time: 1 year Work experience: 1 day a week</p>	<p><u>The College of West Anglia</u></p> <p>Edexcel (BTEC) First Diploma Wildlife and Countryside Care Full-time: 1 year – 4 days a week in college Work experience: included Venue: Wisbech or Milton</p>	<p><u>Shuttleworth College</u></p> <p>Edexcel (BTEC) First Diploma Countryside Studies Full-time: 1 year – 4 days a week in college Work experience: 1 day a week</p>	<p><u>Writtle College</u></p> <p>Edexcel (BTEC) First Diploma Countryside and Forestry Full-time: 1 year – 4 days a week in college Work experience: included</p>
---	--	---	---

City and Guilds Arboriculture

This course is highly respected by employers and will give the students the chance to become a professional arborist. It will give you a comprehensive understanding of both the theoretical and practical aspects of arboriculture, as well as industry standard training in health and safety.

Entry Requirements:

Be employed within the horticulture or arboriculture industry

Age:

16 years +

Must be:

Interested in subject area

Areas of study may include

- Tree identification
- Tree and shrub diseases
- Legal aspects
- Roadside working
- Health and Safety

Participating institutions

Writtle College

**City and Guilds Phase 2
Arboriculture**

Part-time: 1 year

NVQ Level 2

The NVQ Level 2 is aimed at students with some basic experience in the conservation sector who want to gain a work-based qualification and expand their industrial knowledge. Students will usually be employed within the industry or take part in relevant voluntary work. Assessment takes place against the national standard by observation of practical tasks, assignments and building up a portfolio of evidence.

Entry Requirements:

No formal qualifications are required, although students will need a suitable level of literacy and numeracy

Age:

16 years +

Must be:

In suitable employment or have work experience within the industry

Areas of study may include

- Habitat and landscape management
- Maintaining environmental good practice
- Health and safety
- Communication with visitors

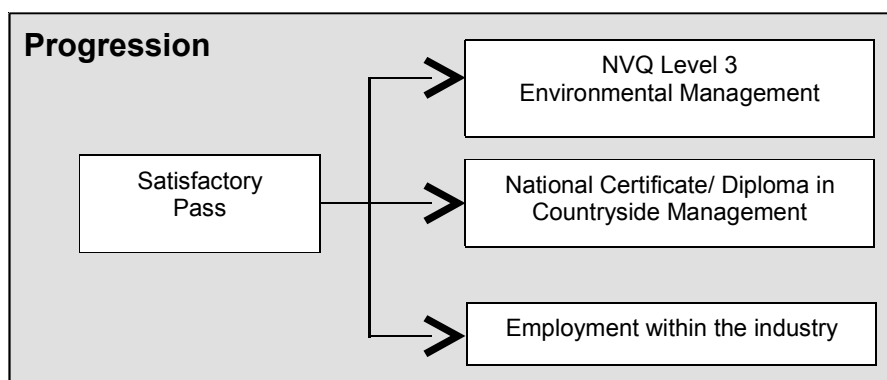

Participating institutions

Easton College

**NVQ Level 2
Forestry and
Woodland
Management**
Part-time: 12 to 18
months – 1 day a
week in college

**NVQ Level 2
Gamekeeping**
Part-time: 1 year +
– 1 day a week in
college

Writtle College

**NVQ Level 2
Environmental
Conservation***
Part-time: 1 year +
– 1 day a week in
college

* **Also available as an Apprenticeship.**

National Certificate

A one year full-time or two year part-time course that provides a highly practical introduction to conservation. Students are introduced to a wide range of conservation and countryside management issues, undertaking a number of assignments and major projects.

Entry Requirements:

Studied to GCSE level

First Diploma in a relevant subject

Relevant experience

Age:

17 years +

Must be:

Interested in the subject area

Areas of study may include

- Records and supervision
- Estate maintenance skills
- Plant identification and applied diagnosis
- Plant and soil science / machinery

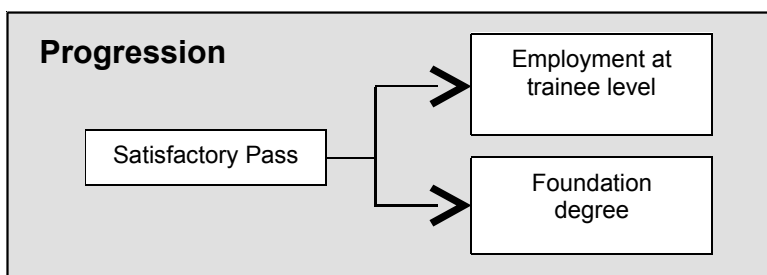

Participating institutions

Otley College

**C&G National Certificate
Environmental Conservation**

Full-time: 1 year

**Work experience:
included**

National Diploma

Equivalent to studying at A level, the National Diploma consists of a number of core and optional units from which students can choose a distinct vocational pathway. The course is usually assignment based, with practical assessments and regular plant identification tests.

Entry Requirements:

4 GCSEs C+

First Diploma in Countryside Conservation

NVQ Level 2 Environmental Conservation

Relevant National Certificate

GNVQ Intermediate Land and Environment

Relevance experience

Mature entry

Age:

16 years +

Must be:

Interested in a career within the industry

Areas of study may include

- Ecology and conservation
- Environmental interpretation
- Environmental science
- Estate skills / land use
- Environmental issues and policies

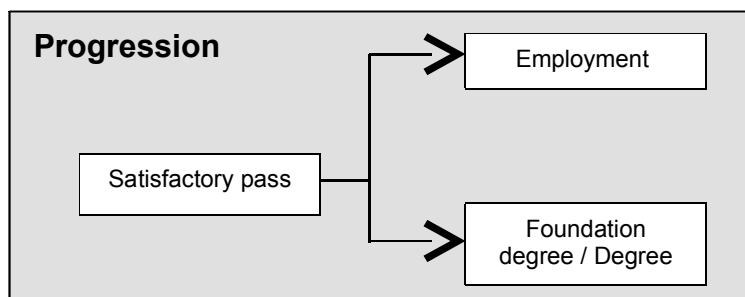

Participating institutions

Easton College

**Edexcel (BTEC)
National Diploma
Countryside
Management**
Full-time: 2 years – 4
days a week in college
Work experience: 1
day a week

**Edexcel (BTEC)
National Diploma
Forestry and
Arboriculture**
Full-time: 2 years – 4
days a week in college
Work experience: 1
day a week

Otley College

**Edexcel (BTEC)
National Diploma
Countryside
Management**
Full-time: 1 year

**BTEC National
Award Countryside
Management
(Woodland
Management)**
Full-time: 1 year

The College Of West Anglia

**Edexcel (BTEC)
National Diploma
Wildlife and
Countryside
Management**
Full-time: 2 years –
5 days a week in
college
Venue: Wisbech and
Milton

Writtle College

**Edexcel (BTEC)
National Diploma
Countryside
Management**
Full-time: 2 years

Shuttleworth College

**Edexcel (BTEC) National Diploma Countryside
Management**
Full-time: 2 years

NVQ Level 3

The NVQ Level 3 is aimed at those already employed within the conservation sector, at a supervisory level, who wish to gain a recognised work-based qualification. This is a part-time course, assessed by observation and practical activities and a portfolio of evidence.

Entry Requirements:

NVQ Level 2 Environmental Conservation

Age:

16 years +

Must be:

Employed within the sector

Areas of study may include

- Ecology
- Conservation management
- Project and organisational management
- Visitor centre sites control
- Health and safety management
- Information gathering and evaluation

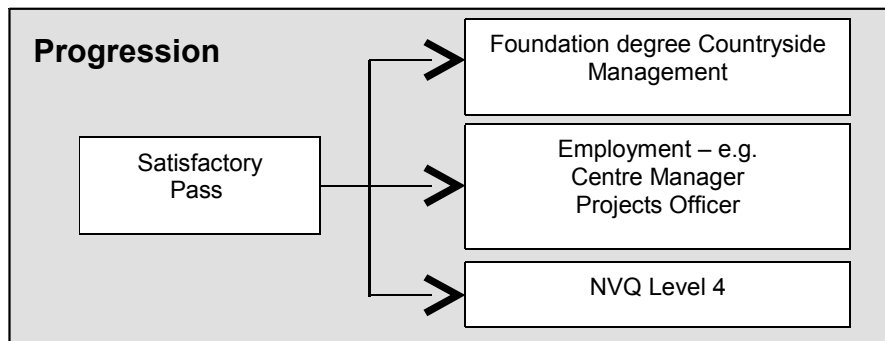

Participating institutions

Easton College

**NVQ Level 3
Gamekeeping**
Part-time: 1 to 2
years

Writtle College

**NVQ Level 3
Environmental
Conservation**
Part-time: 1 to 2
years
Work experience:
Included in
programme

Choosing a Higher Education Course in Countryside Management and Environmental Conservation

Foundation degree

The importance of conservation and the environment is increasingly being recognised. This course provides an understanding of the countryside and the pressure that both wildlife and the environment are facing. The main emphasis for the course is to balance the often competing needs of the countryside with that of recreational visitors and understand current issues associated with the environment and conservation

Entry Requirements:

40 UCAS tariff points

A maximum of 20 tariff points will be counted from Key Skills

Mature students with some formal qualifications and two years or more relevant experience will also be considered.

Age:

18 years +

Must be:

Interested in the subject area

Areas of study may include

- Leisure and education
- Biological processes
- Education and outdoor studies
- Event management
- Animal ecology
- Terrestrial environments
- Ecological survey techniques

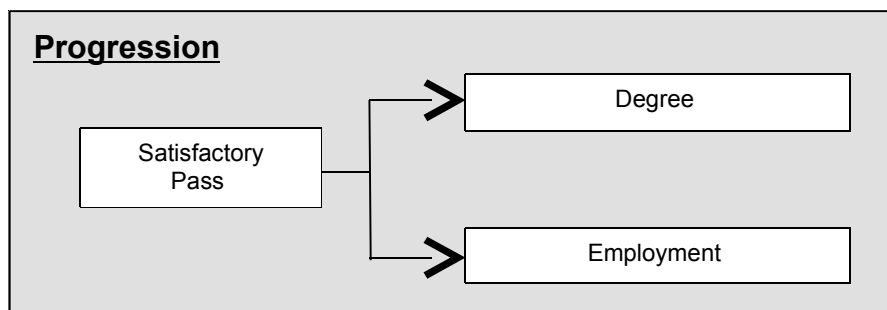

Participating institutions

Easton College

Currently HNC/HND programmes on offer but will change to Foundation degrees from Sept 2006

Writtle College

FdSc Conservation and Environment
UCAS code: D446

FdA Outdoor Recreation and Conservation
UCAS code: ND84

Full-time: 1 year
This course can be studied on a part-time basis

Otley College

FdSc Species and Ecosystem Conservation
Full-time: 2 years
- 1 day a week in college

Honours degree

Degree level courses are aimed at developing vocational and academic skills within the environmental / conservation sector. Students will be trained to apply business knowledge and / or scientific principles to their specialist area, while having the opportunity to gain broader skills within the industry.

Entry Requirements:

Studied to A level

National Diploma / Certificate relevant subject

GNVQ Advanced in relevant subject

Access to HE course / Foundation Science

Mature entry

Age:

18 years +

Must be:

Interested in a career within the environment

Areas of study may include

- Countryside in Britain
- Habitat conservation and interpretation
- Planning, heritage and rural development
- Environmental issues
- Faunal survey techniques
- Pollution – cause and effect

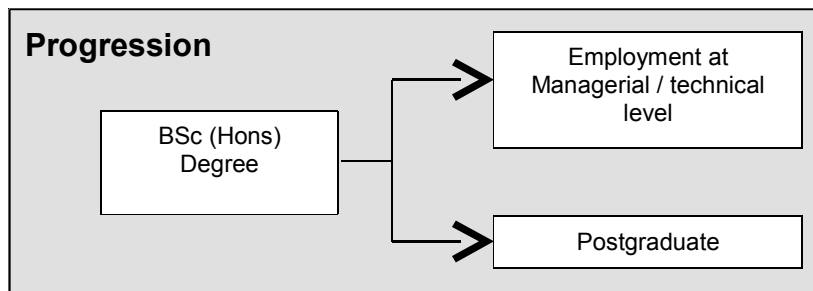

Participating institutions

Writtle College

BSc (Hons) Rural Resource Management

UCAS code: D444

Full-time: 3 years

BSc (Hons) Conservation and Environment

UCAS code: D447

Full-time: 3 years

BSc (Hons) Wildlife Management

UCAS code: DNL2

Full-time: 3 years

BA (Hons) Outdoor Recreation and Conservation (subject to validation)

UCAS code: ND8K

Full-time: 3 years

Part-time study also available

Short Courses

There are a number of part-time leisure and vocational courses available in East Anglia. These are suitable for mature candidates at all levels, from those already working in industry to those with an interest in the area.

Formal qualifications are not usually required, though some of the more advanced courses may expect students to have some previous practical experience. Individuals will be expected to purchase their own materials for the practical lessons and should enquire as to cost and availability prior to joining a course. Participation in a hobby course can lead to progression to further levels of study and a formal qualification.

Please note that institutions may change or cancel courses if necessary and other colleges and organisations, not included, may also run courses locally.

Participating institutions

Otley College

Holds short courses at different times of the year, including those with a conservation and countryside related theme.

Writtle College

Holds short courses related to countryside and conservation at certain times of the year.

Easton College

Chainsaw training (Lantra and NPTC)
Forklift Training (Lantra/CITB/CPCS)
Pesticide Spraying (PA series) (NPTC)
Pest Control

Design

Introduction

The aim of design is to combine creativity, technical skills and art to create dynamic and functional environments, spaces and products for human activity.

The desire to shape our surroundings and create usable and beautiful objects has always existed. At every stage of history, people have used the materials and techniques at their disposal to enhance their surroundings reflecting cultural, technological and increasingly sustainable needs. Along with the desire to combine function and decoration, the basic principles relative to the human scale remain unchanged.

Nowadays more than ever before we are preoccupied with the design of our own personal spaces. The growing public interest in interior design, architecture, horticulture, landscape and garden design and urban and rural regeneration projects have brought the design of our living and working environments into the spotlight. This, in turn, has created more employment possibilities for those with appropriate design skills and qualifications.

Spatial design utilises a range of 2 and 3 dimensional design techniques, which can be applied to many diverse design fields, including domestic settings, theatre, film or TV set design and virtual design exhibitions. Spatial design can also be applied to promotions, gardens, landscapes, interiors and environmental art in the urban and rural context. Within these design sectors there is a demand for highly creative graduates with the managerial, technical, administrative and project management skills to co-ordinate projects from conception to completion. This is why courses are designed to provide students with professional practice experience and commercial awareness to complement their creative abilities and design training.

Further Education

Qualification	Level	Course Title	Page
ABC Certificate / College Certificate	2	<ul style="list-style-type: none"> • Interior Design • Garden Design 	62
C&G Certificate	2 & 3	<ul style="list-style-type: none"> • Practical Garden Design • Planning a Room 	63
Centra Certificate	2	<ul style="list-style-type: none"> • Art, Design and Creative Studies – Interior Design 	64
National Diploma / Certificate / Advanced National Diploma	3	<ul style="list-style-type: none"> • 3D Design • Graphic Design • Art and Design • Landscape Design • Horticulture – Garden Design Specialism 	65

Higher Education

Qualification	Course Title	Page
Foundation degree (Replacing HND/HNC)	<ul style="list-style-type: none"> • FdSc Garden Design • FdA Spatial Design and 3D Design • FdA Visual Design Communication 	66
Degree	<ul style="list-style-type: none"> • BSc (Hons) Landscape and Garden Design • BSc (Hons) Garden Design, Restoration and Management • BA (Hons) Interior Design 	67

Miscellaneous

Short and Leisure Courses	Page
<ul style="list-style-type: none"> • Principles of Garden Design 	68

Linking Subjects

A **design** course can allow progression into other subject areas

Course
<ul style="list-style-type: none"> • Horticulture

Choosing a Further Education course in Design

ABC Certificate / College Certificate

To provide the basic knowledge and skills required within the principles of interior design. Assessment is based on assignments throughout the year with a final project being a culmination of all areas covered.

Entry Requirements:
No formal qualifications
Mature entry
Age:
16 years +
Must be:
Interested in working in design

Areas of study may include

- Presentation drawing
- Colour
- History of interior design
- Lighting, furniture, floor and wall coverings
- Horticulture
- Basic principles of design

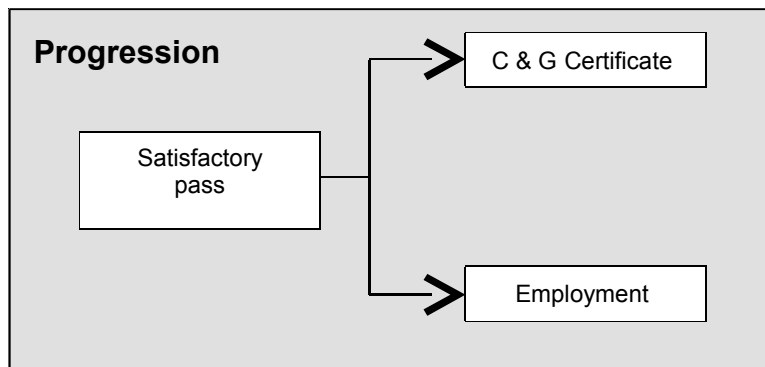

Participating institutions

Otley College

**College Certificate
Garden Design
Full-time: 1 year**

Easton College

**ABC Certificate
Interior Design
Part-time: 1 year - 1
day a week in college**

City & Guilds Certificate

To provide the basic knowledge and skills required to design and construct a design area. The programme will also look at the past influences on design. Evaluation is by continuous assessment, end of module tests and practical tasks.

Entry Requirements:

No formal entry requirements

Age:

16 years +

Must be:

Interested in subject area

Areas of study may include

- Basic principles of design
- Principles of construction
- Graphic drawing
- Horticulture
- Business management
- Graphics and symbols

Progression

Satisfactory pass

National Certificate /
Diploma

Employment at junior
level

Participating institutions

Otley College

C&G 7822
Planning a room –
Level 2
Part-time: 1 year –
1 day a week in
college

Easton College

C&G Certificate
Practical Garden
Design
Part-time: 1 year – 1
day a week in
college

C&G Level 1
Certificate Practical
Garden Design
Part-time: 1 year – 1
day a week in
college

C&G Level 2 Craft
Skills Certificate
Garden Design
Part-time: 1 year – 1
day / evening a week
in college

Shuttleworth College

C&G Design and
Craft Certificate
Level 2 Planning a
Room
Full-time: 1 year –
evenings

C&G Design and
Craft Certificate
Level 3 Planning a
Room
Full-time: 1 year

Centra Certificate

This is an introductory level course, which is designed for students looking to begin a career in the interior design industry, or for those wanting to start a new hobby.

Entry Requirements:

No formal qualifications required

Age:

16 years +

Must be:

Keen and interested in interior design

Areas of study may include

- 2D and 3D design visual language
- Design development
- Personal contextual investigation and interior design

Progression

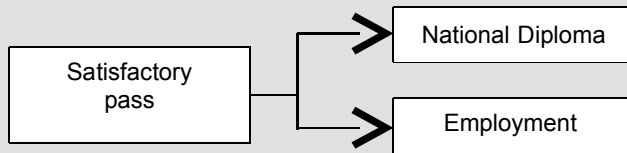

Participating institutions

Writtle College

**Centra Certificate Art,
Design and Creative
Studies – Interior
Design**

Part-time: 1 year – 1
day a week in college

National Diploma / Certificate / Advanced National Diploma

A one or two year course for school leavers with a number of GCSEs or for mature returners wanting a career in the design industry at a supervisory level

Entry Requirements:

4 GCSEs C+ (English, Maths, Science)
GNVQ Intermediate in a relevant subject (Pass)
Mature entry/relevant work experience

Age:

16 years +

Must be:

Interested in working within design

Areas of study may include

- Methods and principles of design
- Drawing development
- Historical and contextual studies
- Computers in art and design
- Materials and techniques
- Visual communications

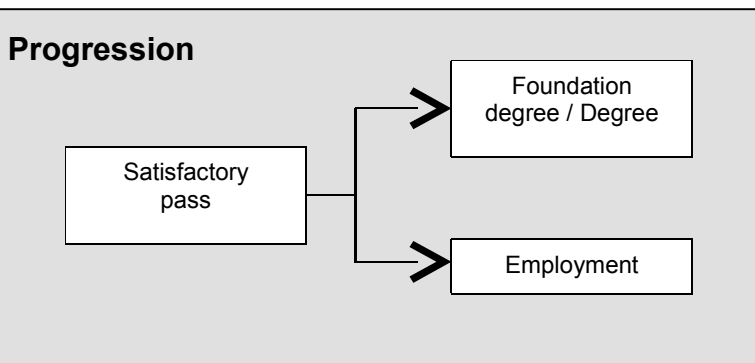

Participating institutions

<p><u>Easton College</u></p> <p>National Certificate Horticulture – Garden Design Specialism Full-time: 2 years – 1 day a week in college</p> <p>National Award Horticulture – Garden Design Specialism Part-time: 1 year – 1 day a week in college</p>	<p><u>The College of West Anglia</u></p> <p>Edexcel (BTEC) National Diploma Graphic Design Full-time: 2 years Venue: King's Lynn</p> <p>Edexcel (BTEC) National Diploma / Foundation Studies (Art and Design) Full-time: 1 year Venue: King's Lynn</p>	<p><u>Otley College</u></p> <p>Advanced National Certificate Landscape Design Full-time: 1 year Part-time: 2 years</p>	<p><u>Writtle College</u></p> <p>Edexcel (BTEC) National Diploma 3D Design Full-time: 2 years</p>
		<p><u>Shuttleworth College</u></p> <p>Edexcel (BTEC) National Diploma 3D Design Full-time: 2 years</p>	

Choosing a Higher Education course in Design

Foundation degree

These courses are aimed at developing vocational and academic skills in the design sector. Students will be trained to apply scientific principles to their specialist area, while having the opportunity to gain broader skills in a variety of areas.

Entry Requirements:
 60 UCAS tariff points
 A maximum of 20 tariff points will be counted from Key Skills
 Mature students with some formal qualifications but with experience of agriculture are encouraged to apply

Age:
 18 years +

Must be:
 Interested in the subject

Areas of study may include

- Visual design communication
- Spatial design studies
- Design culture
- Creative digital technologies
- Professional design practice
- Vocational focus study
- Detail design for gardens
- Planting and horticultural design

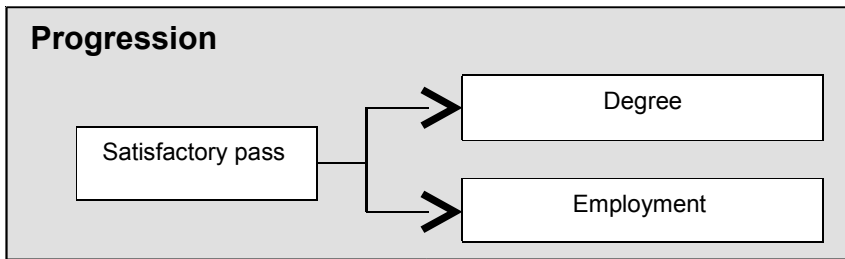

Participating institutions

<p><u>Oltey College</u></p> <p>FdA Landscape and Garden Design Full-time: 2 years – 1 day a week in college Part-time: over 4 years</p>	<p><u>Writtle College</u></p> <p>FdA Spatial Design and 3D Design UCAS Code: W290 Full-time: 2 years Part-time: over 4 years</p> <p>FdA Visual Design Communication UCAS Code: W291 Full-time: 2 years Part-time: over 4 years</p> <p>FdSc Garden Design UCAS Code: DK44 Full-time: 2 years Part-time: over 4 years</p>	<p><u>Easton College</u></p> <p>Currently HNC/HND programmes on offer but will change to Foundation degrees from Sept 2006, full and part-time</p>
---	---	---

Honours degree

These degree level courses are aimed at developing vocational and academic skills in the design sector. Students will be trained to apply scientific principles to their specialist area, while having the opportunity to gain broader skills in a variety of areas.

Entry Requirements:

A levels

National Diploma

GNVQ (Merit / Distinction)

Relevant Foundation degree or HND (High Pass)

Relevant work experience / mature entry

Age:

18 years +

Must be:

Interested in design

Areas of study may include

- Visual and design communications
- Spatial design studies
- Horticultural technology
- Conservation and restoration of historic gardens
- Landscape planning and law

Progression

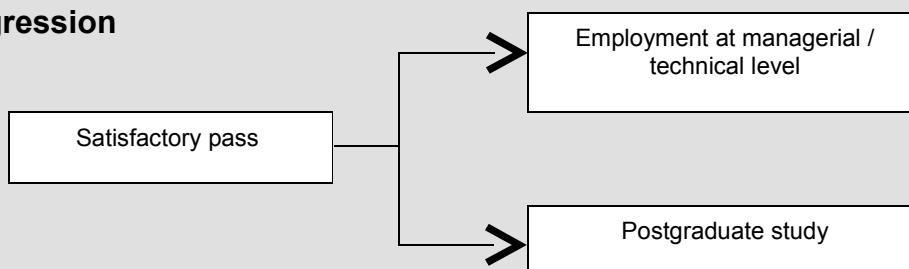

Participating institutions

Writtle College

BSc (Hons) Landscape and Garden Design
UCAS Code: K3210
Full-time: 3 years

BSc (Hons) Garden Design, Restoration and Management
UCAS Code: KN32
Full-time: 3 years

BA (Hons) Interior Design
UCAS Code: W250
Full-time: 3 years

Part-time study also available

Short Courses

A number of colleges run short courses in design. These are stand-alone courses, which can lead on to further qualifications.

Please note that these courses may be subject to change at any time.

Formal qualifications are not usually required, though some of the more advanced courses may expect students to have some previous practical studies.

Participating institutions

Writtle College

Principles of Garden
Design

Floristry

Introduction

Floristry is an expanding industry with openings to suit a range of abilities. There are career opportunities from small, local retail outlets to international businesses and considerable scope for self-employment after a few years.

The industry is dynamic, following fashion trends and the seasons. Many floristry businesses are small and have one or two shops. Materials are expensive and by their nature have a short shelf life. Wages within the industry are not particularly high, with staff receiving about the same as most retail employees.

Potential students need patience, dedication, an artistic ability and manual dexterity. They will be required to gain a thorough knowledge of plants and flowers. An important part of the floristry business is the need of the customer, so employees will need to develop good communication skills and business sense. Not only does a florist create and produce designs, but must also purchase the raw materials, take orders and collect payments. This may involve using information technology such as computers and the internet.

Floristry students may have to purchase raw materials for each practical session and should plan for this accordingly. Some colleges offer materials at cost or reduced price and have facilities for storage. Students undertake work experience at local florists, which is essential to gain experience and progress to further qualifications. The industry has a number of its own qualifications, such as the Society of Floristry Intermediate Certificate or National Diploma. The latter is the industry's highest award and only held by a select few.

A large number of hobby courses are available in floristry and flower arranging, which are suitable for the complete beginner.

Interior plantscaping is becoming a high growth industry at present, originating in the USA. This is linked with the amenity sector of horticulture, creating features and landscapes within artificial settings such as shopping centres, hotels and company buildings. Larger firms can offer a full service of design, installation and maintenance.

Further Education

Qualification	Level	Course Title	Page
Foundation	Entry	<ul style="list-style-type: none"> • Floral Styling 	71
First Diploma	2	<ul style="list-style-type: none"> • Floristry • Award Floristry 	72
NVQ Level 2	2	<ul style="list-style-type: none"> • Floristry • Flower Arranging 	73
National Certificate	2/3	<ul style="list-style-type: none"> • Floristry 	74
Advanced National Diploma / Certificate	2 and 3	<ul style="list-style-type: none"> • Floristry 	75
NVQ Level 3	3	<ul style="list-style-type: none"> • Floristry 	76
City and Guilds	1, 2 and 3	<ul style="list-style-type: none"> • Floristry • Flower Arranging • Additional Floristry Techniques 	77
NAFAS Award	1, 2 and 3	<ul style="list-style-type: none"> • Introduction to Flower Arranging • Extended Flower Arranging • Advanced Flower Arranging • Floral Design • Advanced Flower Design 	78

Higher Education

Qualification	Course Title	Page
Foundation degree (replacing HND/HNC)	<ul style="list-style-type: none"> • FdSc Professional Floristry 	79

Miscellaneous

Short and Leisure Courses	Page
<ul style="list-style-type: none"> • Floral/Art • Floristry • Flower Arranging • Flower Decorations 	80

Linking subjects

A **floristry** course can allow progression into other subject areas.

Course
<ul style="list-style-type: none"> • Horticulture • Interior Design

Choosing a Further Education Course in Floristry

Foundation Level

Aimed at those with little or no formal qualifications. This is an introduction to working within the floristry industry while continuing to develop basic educational skills.

A high level of student support is given and students are instructed in communication, numeracy and life skills.

Entry Requirements:

No formal qualifications are needed

Age:

16 years +

Must be:

Interested in floristry

Areas of study may include

- Basic floristry skills
- Health and safety
- Numeracy
- Life skills
- Communication
- Care and conditioning
- Preservation methods

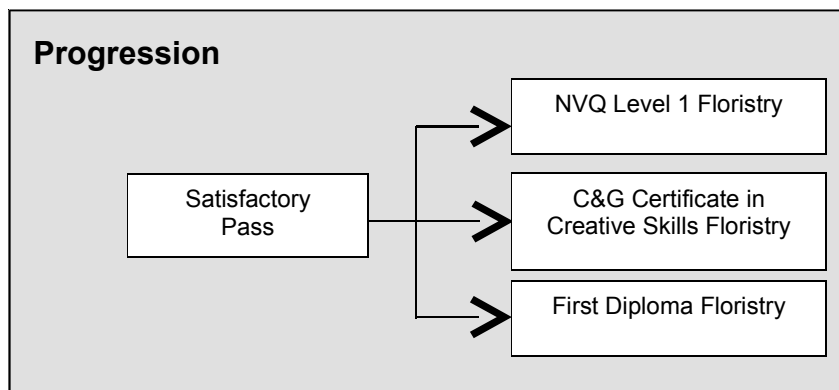

Participating institutions

Easton College

C&G First steps in Floral Styling

Availability: 5 day course in July or 1 evening a week for 10 weeks.

Work experience: Included

First Diploma

This programme offers a solid foundation of skills and knowledge for students who wish to join and establish a career within the floristry industry. The courses aim to provide a basic introduction to both practical and theoretical elements of floristry.

Entry Requirements:

Studied to GCSE Level
Foundation in Land-Based Industries
Previous relevant experience

Age:

16 years +

Must be:

Enthusiastic and interested in working within the floristry industry

Areas of study may include

- Flower care and presentation
- Floral design techniques
- Arrangements for functions and occasions
- Flower and foliage identification

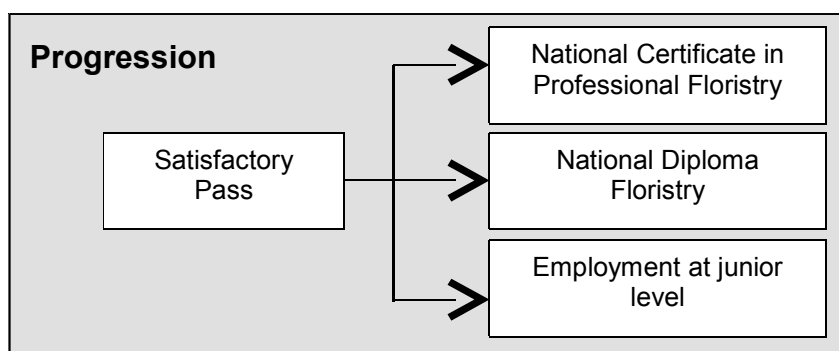

Participating institutions

<p><u>Easton College</u></p> <p>Edexcel (BTEC) First Diploma Floristry Full-time: 1 year – 3 to 5 days a week in college Work experience: 1 day a week</p>	<p><u>Shuttleworth College</u></p> <p>Edexcel (BTEC) Award Floristry Part-time: 1 year – 1 day a week in college Work experience: 5 days</p>	<p><u>The College of West Anglia</u></p> <p>Edexcel (BTEC) First Diploma Floristry Full-time: 1 year – 5 days a week in college Part-time: 2 years – 1 day a week in college Work experience: Floristry shop and hotel work Venue: Wisbech or Milton</p>
--	--	--

NVQ Level 2

A broad based programme that provides students with floristry and retailing skills. Open to those employed within the industry and ideal for trainees new to the floristry industry. The award is made up of ten units.

Entry Requirements:

No formal qualifications are required
Students should be working within the industry or have a suitable work placement

Age:

16 years +

Must be:

Interested in the subject and have an artistic flair

Areas of study may include

- Care and condition of the product
- Funeral tributes
- Wedding designs
- Plants and foliage
- Window work
- Costing of designs
- Flower arranging
- Gift packaging
- Hand-tied bouquets
- Customer care
- Sales and stock control
- Health and safety

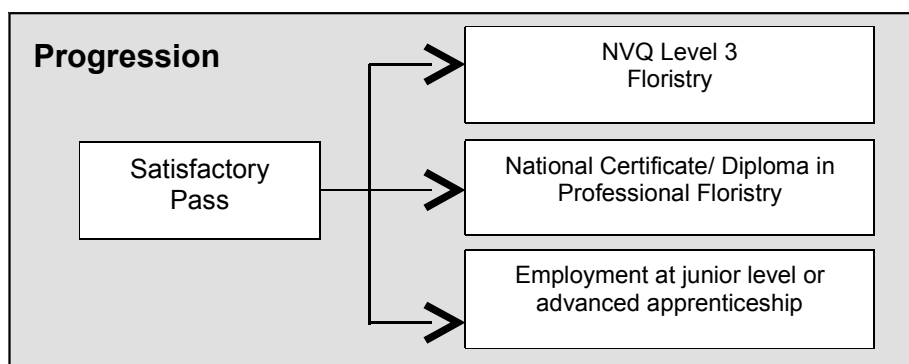

Participating institutions

Easton College

NVQ Level 2 Floristry

Part-time: 1 day a week.

Apprenticeship: 4 days' work placement 1 day at college for 12 – 18 months

Otley College

C&G NVQ Level 2 Flower Arranging

Part-time: 1 day a week

The College of West Anglia

C&G NVQ Level 2 Floristry

Part-time: 2 years – 1 day a week in college

Venue: Milton and Wisbech

National Certificate

The City and Guilds qualification is ideal for those wishing to update their skills within the industry. It aims to develop students in advanced levels of design, floristry, retail and managerial skills. The Edexcel course is aimed at the beginner wishing to start a career within commercial floristry. Both the Edexcel and City and Guilds programmes offer a mixture of practical and theory. The content is also designed to allow progression towards the Society of Floristry qualifications.

Entry Requirements:

NVQ Level 2 Floristry

GCSEs

First Diploma Floristry

2 years practical floristry experience

Age:

16 years + (Edexcel) 17 years + (C&G)

Must be:

Self disciplined and motivated

Areas of study may include

- Wedding / presentation designs
- Funeral and sympathy designs
- Gift work and accessories / flower arranging
- Special functions and contract design
- Visual studies / business and retailing
- Care and control of stock / health and safety
- Floriculture / interior landscaping

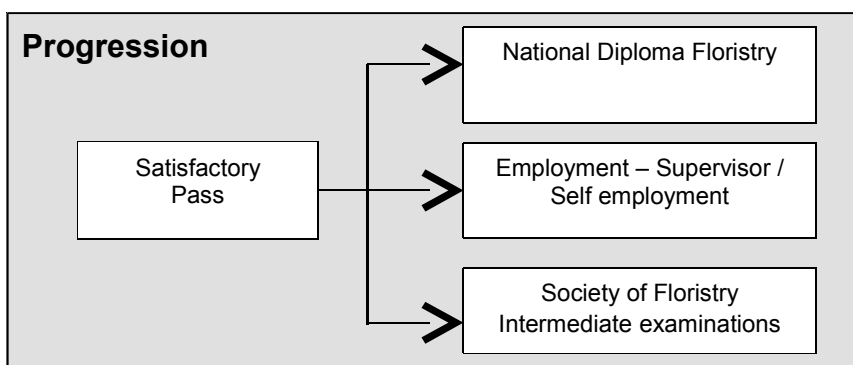

Participating institutions

Easton College

**Edexcel (BTEC)
National
Certificate
Floristry**
Part-time: 2 years
– 1 day a week in
college

Shuttleworth College

**C&G National
Certificate in
Floristry**
Part-time: 1 year –
5 days a week in
college
Work Experience:
Included in
programme

Writtle College

**C&G National
Certificate
Floristry**
Full-time: 1 year
Part-time: 2 years
Work Experience:
Incorporated

Advanced National Diploma / Certificate

This course is aimed at school leavers or mature returners to education who wish to develop advanced floristry and design skills, while gaining knowledge of the work involved in running a business in floristry or design.

Entry Requirements:

4 GCSEs C+ (English, Maths, Science)

First Diploma (Merit/Distinction)

National Certificate (Professional) Floristry to enter at year 2

Mature entry

Age:

16 years +

Must be:

Interested in a career within the industry

Areas of study may include

- Assembled designs (wired, tied and gift wrapped)
- Plant and soil science
- Display techniques
- Multicultural designs
- Wedding designs
- Funeral tribute designs
- Business and IT / marketing and research
- Flowering and foliage plants
- Issues and legislation in floristry

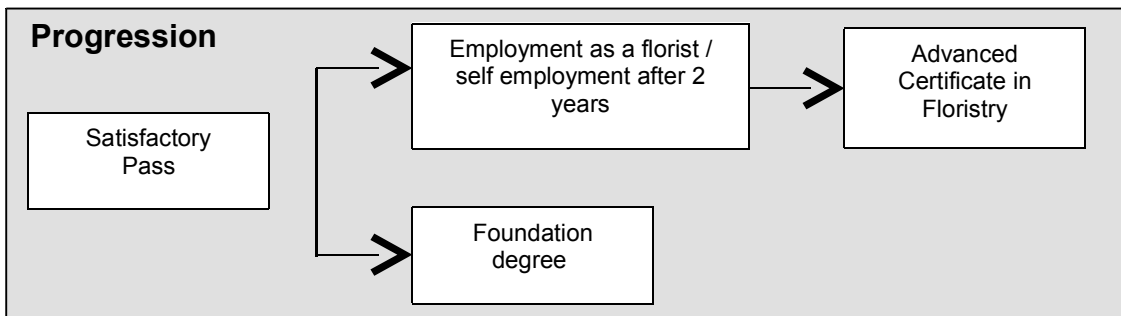

Participating institutions

The College of West Anglia

C&G Advanced Certificate Professional Floristry

Full-time: 2 years – 3 to 4 days a week in college

Part-time: Associate Student Learners' Programme

Work experience: 10 weeks over 2 years

Edexcel (BTEC) National Diploma Floristry

Full-time: 2 years – 2 to 3 days a week in college

Work experience: 1 day a week + one block week

Shuttleworth College

C&G Advanced National Certificate Floristry

Part-time: 2 years – one day a week in college

Work experience: included

Writtle College

Edexcel (BTEC) Advanced National Certificate Floristry

Full-time: 1 year

Part-time: 2 years

Work experience: is not required but assistance is available if you want to gain additional work experience

NVQ Level 3

The NVQ Level 3 is aimed at those already employed within the floristry industry, at a supervisory / managerial level, who wish to gain a recognised work-based qualification. This is usually a part-time course, assessed by observation and practical activities and a portfolio of evidence. It builds on the knowledge and skills gained at Level 2.

Entry Requirements:

NVQ Level 2 Floristry (Pass)
Relevant prior experience

Age:

16 years +

Must be:

Employed within the industry at supervisory level

Areas of study may include

- Gift work and accessories
- Continental designs
- Care and conditioning of flowers
- Sale of floristry products
- Control or the receipt of payment
- Packing and wrapping floristry designs
- Master class flower arranging

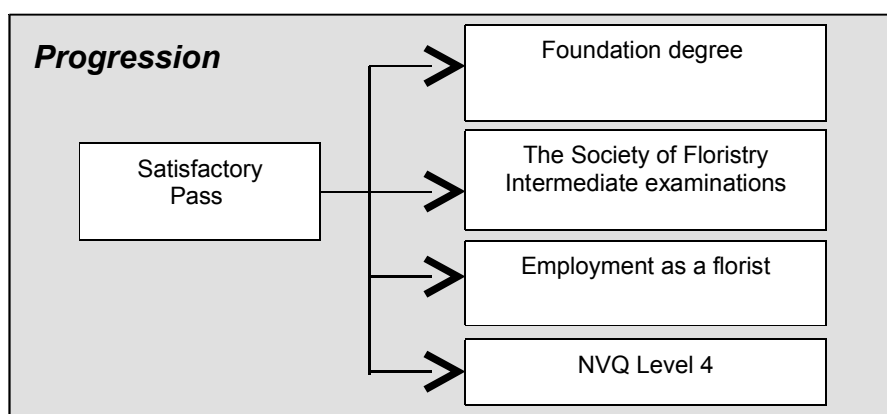

Participating institution

Easton College

C&G NVQ Level 3 Floristry

Part-time: 2 years –
1 day a week in college

City and Guilds Creative Skills / Studies Certificates

C&G Creative Skills Certificates

Aimed at complete beginners, this course provides an introduction to plant classification, mechanics, materials and flower arranging techniques. No prior knowledge of the subject is needed unless stated. On successful completion candidates can then progress to a Creative Studies (Part 1) qualification or NVQ Level 2 Floristry if in employment.

C&G Creative Studies Certificates

This is a more advanced qualification than the Creative Skills certificates and assumes that candidates have previous experience and qualifications. The course is usually in two parts. Successful candidates can progress from Part 1 to Part 2.

Participating institutions

Easton College

C&G Creative Skills Certificate Floristry
Part-time: 1 year – 1 day a week in college

The College Of West Anglia

OCN Floristry
Part-time: 2 years – 1 day a week in college

Shuttleworth College

C&G Creative Skills Certificate Flower Arranging
Part-time: 1 year – 1 half day or evening a week

Writtle College

C&G Certificate Design and Craft – First Steps in Floristry
Part-time: 1 year

C&G Certificate in Design and Craft –Floristry
Full-time: 1 week

C&G Certificates also available in
Additional Floristry Techniques
Interior Floral Design
Flower Arranging: Part 1 and 2
Basic Photography
Contemporary Floral Design
Flower Arranging
Retail/Window Display
Balloon Display

There are a number of qualifications available validated within the floristry industry, such as the National Association of Flower Arranging Societies (NAFAS) and the Society of Floristry. These range from entry level to the vocational equivalent of higher educational study.

Entry Requirements:

NVQ Level 2 Floristry

NAFAS Level 1 or basic knowledge of flower arranging

Age:

16 years +

Areas of study may include

- Historical fashions
- Interior design and styling skills
- Commercial practical floristry provision within the business
- Geometric and British freestyle designs
- Correct choices and uses of tools
- Floristry of off-site events including interior landscaping
- World influences
- Abstract / show work
- Botany and horticulture

Participating institutions**Easton College****NAFAS Basic Floral Design**

Part-time: 1 year - 1 day a week in college

NAFAS Advanced Floral Design

Part-time: 2 years - 1 day a week in college

Easton College**NAFAS Level 1 Introduction of Flower Arranging**

Part-time: 8 weeks – 1 day a week in college

Progression: NAFAS Level 2

NAFAS Level 2 Basic Floral Design

Part-time: 30 weeks – 1 day a week in college

Progression: NAFAS Level 3

NAFAS Level 2 – Extended Flower Arranging

Part-time: 20 weeks – 1 day a week in college

Progression: NAFAS Level 3

NAFAS Level 2: Floral Design

Part-time: 30 weeks – 1 day a week in college

Progression: NAFAS Advanced

NAFAS Level 3 – Advanced Floral Design

Part-time: 60 weeks – 1 day a week in college

Progression: Higher level flower arranging courses

Choosing a Higher Education Course in Floristry

Foundation degree

This course is comprised of three areas of study. The main area is in practical and theoretical aspects of floral design. The second is business management, providing the skills necessary to run a business and the third is plant material and management.

Entry Requirements:

40 UCAS tariff points

A maximum of 20 tariff points will be counted from Key Skills

Mature students with some formal qualifications but with experience of agriculture are encouraged to apply

Age:

16 years +

Must be:

Interested in the subject area

Areas of study may include

- Traditional floristry
- Contemporary floristry
- International dimensions
- Plant production
- Fresh material management
- Retailing/garden centres

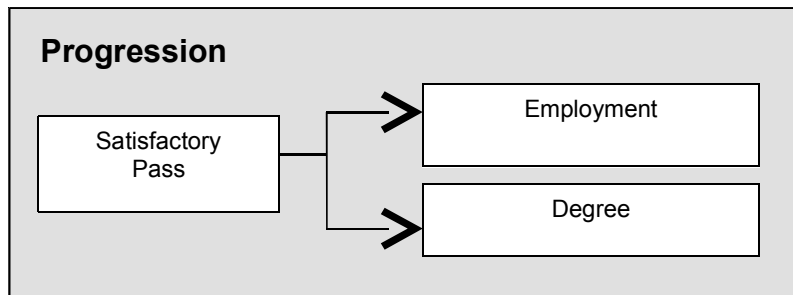

Participating institutions

Writtle College

FdSc Professional Floristry

Full-time: 2 years

Part-time: 4 or more years

Short Courses

There are a number of hobby courses available in floristry and flower arranging around the region. These are normally part-time and differ in length from one day only, to up to one year.

Formal qualifications are not usually required, though some of the more advanced courses may expect students to have some previous practical experience. Individuals will be expected to purchase their own materials for the practical lessons and should enquire as to cost and availability prior to joining a course. Participation in a hobby course can lead to progression onto other levels of study and a formal qualification.

Please note that institutions may change or cancel courses if necessary and other colleges and organisations, not included, may also run courses locally.

Participating institutions

Writtle College

Runs a number of Floristry, Design and Flower Arranging short courses, from beginners level to advanced.

Part-time: 1 day to 10 weeks

Otley College

Runs a number of leisure learning courses in Floristry.

Part-time

Horse Studies

Introduction

The UK equine industry is one of the top three land-related employers. Employment is not limited to practical horse care, but also includes the many supporting industries, such as feed suppliers and saddlers, which actually make up the bulk of career opportunities.

Working directly with horses is not a nine to five job as horses need to be looked after every day of the year, with early starts and weekend shifts. The work is demanding and sometimes physically exerting, but rewarding. The wages at the bottom of the industry, such as for grooms and stable hands, tend to be lower than average but employees can be provided with accommodation, food and clothing. They may also be given the chance to compete in events, use facilities and gain travel opportunities both in the UK and internationally.

The equine industry is especially dominant within East Anglia, which is home to Newmarket, the heart of the thoroughbred and breeding industry. Students are encouraged to gain work experience as part of their course and may gain the opportunity to specialise in certain areas such as riding, livery, breeding, showjumping, trekking, heavy horses, racing, hunting and eventing. This can lead to a job within the industry as a groom, instructor, farrier or competitor or even within the armed forces.

Usually, potential students are expected to be fairly fit, have some previous experience with horses and show dedication and commitment. It is not always necessary to be able to ride before joining a course, but previous experience is preferred. Students are usually expected to undertake yard duties and are required to have a genuine interest in horses and their welfare.

Certain careers available within the industry do not involve direct practical horse care or riding. Higher level career opportunities have a scientific or management background and are available in such areas as bloodstock administration, equine nutrition, financial management or working within the media.

Equine courses not only allow students to develop their horse knowledge and practical techniques in order to meet the needs of modern employment, but also to gain skills in management, IT and administration.

Further Education

Qualification	Level	Course Title	Page
Foundation	Entry	<ul style="list-style-type: none"> Horse Care Skills for Working Life 	83
NVQ Level 1	1	<ul style="list-style-type: none"> Horse Care 	84
First Diploma	2	<ul style="list-style-type: none"> Horse Care Horse / Equine Studies 	85
NVQ Level 2	2	<ul style="list-style-type: none"> Horse Care 	86
National Certificate	2 and 3	<ul style="list-style-type: none"> Horse / Equine Studies Management of Horses 	87
National Diploma	3	<ul style="list-style-type: none"> Horse / Equine Studies Management of Horses 	88
NVQ Level 3	3	<ul style="list-style-type: none"> Horse Care Horse Care and Management Horse Management 	89

Higher Education

Qualification	Course Title	Page
Foundation degree (replacing HNC/HND)	<ul style="list-style-type: none"> FdSc Equine Breeding and Stud Management FdSc Equine Science FdSc Equine Studies FdSc Equine Studies and Business Management FdA Equine Studies 	90
Degree	<ul style="list-style-type: none"> BSc (Hons) Equine Studies BSc (Hons) Equine Science BSc (Hons) Equine Studies and Business Management BSc (Hons) Equine Breeding and Stud Management 	91

Miscellaneous

British Horse Society	Page
<ul style="list-style-type: none"> BHS Riding and Road Safety BHS Horse Knowledge, Care and Riding Stages 1 and 2 BHS Preliminary Teaching Preparation BHS Horse Knowledge and Care Stages 3 and 4 	92

Linking subjects

A horse course can allow progression into other subject areas

Course
<ul style="list-style-type: none"> Agriculture Animal Studies

Choosing a Further Education Course in Horse Studies

Foundation Level

Aimed at those with little or no formal qualifications. This is an introduction into vocational education and working with horses, while continuing to develop basic educational skills. A high level of student support is given and students are instructed in communication, numeracy and life skills.

Entry Requirements:

No formal qualifications are needed.

Age:

16 years +

Must be:

Interested in working with horses and continuing with full-time education

Areas of study may include

- Stable management
- Equitation
- Assisting with routine care
- Servicing facilities
- Handling horses from the ground
- Preparing horses for use
- Liaising with callers and colleagues

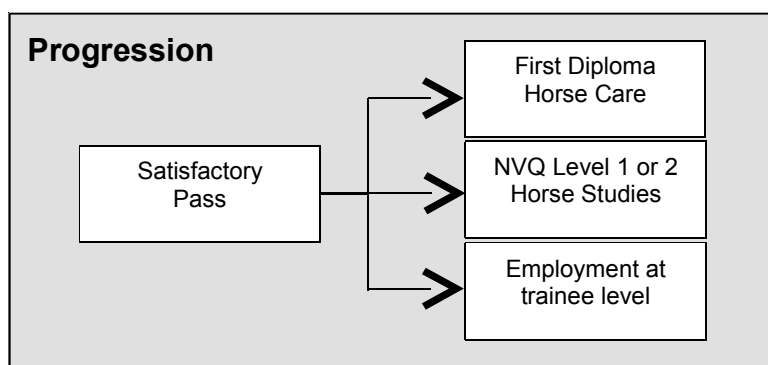

Participating institutions

Easton College

Edexcel Certificate Skills for Working Life

Full-time: 1 year – 4 days a week in college

Otley College

Foundation Horse Care

Full-time: 1 year – 5 days a week in college
Work experience: 1 day a week plus 1 block week

The College of West Anglia

Foundation Horse Care

Full-time: 1 year – 5 days a week in college
Work experience: Included
Venue: Wisbech and Milton

NVQ Level 1

This is a practical qualification, which will aid employment in stable yards. Students build up a portfolio of work and assignments and also show evidence of practical skills in the workplace.

Entry Requirements:

No formal qualifications are needed
Mature students

Age:

16 years +

Must be:

Enthusiastic and dedicated to looking after horses

Areas of study may include

- Care and handling of horses
- Riding skills
- Preparing horses for use under supervision
- First Aid
- Liaising with callers and colleagues

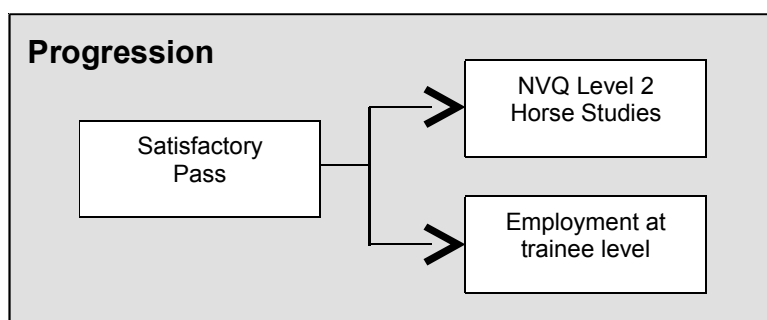

Participating institutions

Easton College

NVQ Level 1 Horse Care

Full-time: 1 year – 4 days a week in college

The College of West Anglia

NVQ Level 1 Horse Care

Part-time: 1 year+

First Diploma

This offers a post-GCSE introduction to the equine industry and aims to develop both theoretical and practical skills. This qualification is suitable for both school leavers and mature candidates wishing to undertake a change of career. Students can expect to undertake a range of duties at the college stables.

Entry Requirements:

No formal qualifications are required but students should have studied to GCSE level in English and Maths
Foundation in Land-Based Industries
NVQ Level 1 Horse Care

Age:

16 years +

Must be:

A member of the BHS to study for their examinations

Areas of study may include

- Equine industry studies
- Business skills/ equitation
- Horse health and nutrition
- Basic horse science and technology
- Grassland management
- Stable management / flatwork and jumping

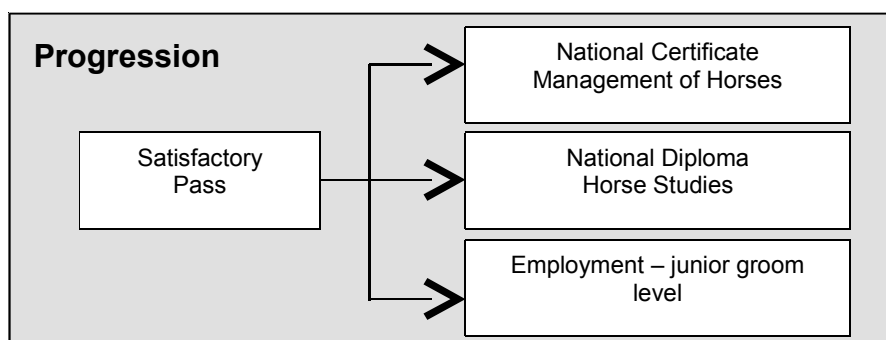

Participating institutions

<p><u>Easton College</u></p> <p>Edexcel (BTEC) First Diploma Horse Care Full-time: 1 year – 4 days a week in college Work experience: 1 day a week in college</p>	<p><u>The College of West Anglia</u></p> <p>Edexcel (BTEC) First Diploma Horse Care Full-time: 1 year – 5 days a week in college Venue: Wisbech or Milton</p>	<p><u>Writtle College</u></p> <p>Edexcel (BTEC) First Diploma Horse Care Full-time: 1 year – 5 days a week in college Work experience: Minimum of 200 hours</p>	<p><u>Shuttleworth College</u></p> <p>Edexcel (BTEC) First Diploma Equine Studies Full-time: 1 year – 5 days a week in college Work experience: 6 week work placement</p>
---	---	---	---

NVQ Level 2

The NVQ Level 2 caters for a wide range of students from the single horse owner to someone who wishes to start a career within the industry. Students are required to prove vocational competence with horses under supervision in line with BHS Stage 2. Candidates are usually required to work within the industry to have a suitable placement

Entry Requirements:

NVQ Level 1 Horse Care
BHS Stage 1 riding or considerable riding experience

Age:

16 years +

Must be:

Interested in working with horses and to improve equine knowledge

Areas of study may include

- Handling the horse
- Preparing horses for use
- Horse knowledge and care
- Health and nutrition
- Shoeing, footcare and trimming
- Grassland management

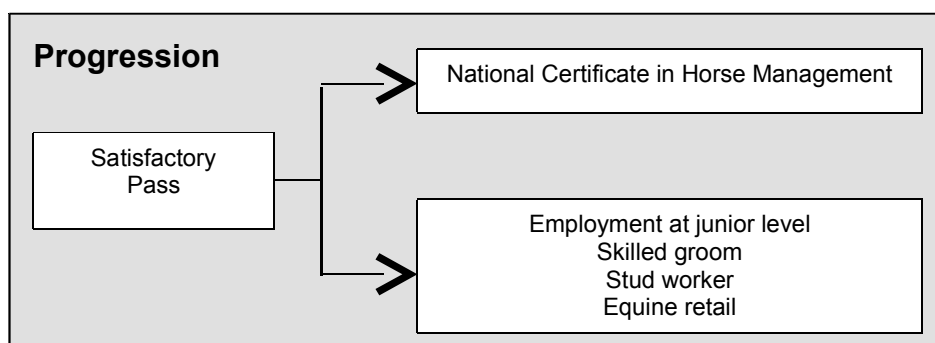

Participating institutions

<p><u>Easton College</u></p> <p>NVQ Level 2 Horse Care* Part-time: 1 year – 1 day a week in college</p>	<p><u>Otley College</u></p> <p>NVQ Level 2 Horse Care Part-time: 1 year or more – 1 day a week in college Apprenticeship only</p>	<p><u>The College of West Anglia</u></p> <p>NVQ Level 2 Horse Care* Part-time: 1 year or more – 1 day a week in college</p>	<p><u>Writtle College</u></p> <p>NVQ Level 2 Horse Care* Part-time: 1 to 2 years – 1 day a week in college</p>	<p><u>Shuttleworth College</u></p> <p>NVQ Level 2 Horse Care* Part-time: Flexible – 1 day a week in college</p>
--	--	--	---	--

* Also available as an Apprenticeship

National Certificate

This course offers a mixture of practical and theoretical instruction, aimed at giving students the opportunity to gain knowledge and develop skills in equitation and horse management up to NVQ level 2 / BHS stage 2 standard. There are two awarding bodies that run the National Certificate in the Management of Horses:

- *City and Guilds – These National Certificates are currently under review and will shortly become a level 2 qualification*
- *Edexcel (BTEC) – These National Certificates are in line with the first year of a National Diploma and are therefore at level 3*

Entry Requirements:

Studied to GCSE level
 First Diploma Horse Studies
 BHS Stage 1 or 2
 Relevant experience with horses

Age:

17 years +

Must be:

Interested in working with horses

Areas of study may include

- Applied science
- Equitation
- Business management
- Equine nutrition, health and disease
- Principles of equine husbandry
- Care of the competition horse

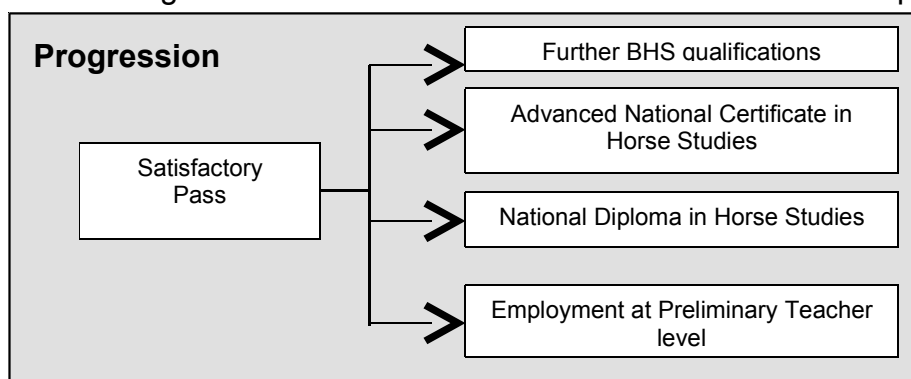

Participating institutions

Otley College

C&G National Certificate Horse Care

Full-time: 1 year – 5 days a week in college

Writtle College

Edexcel (BTEC) National Certificate Management of Horses

Full-time: 1 year – 5 days a week in college

C&G Advanced National Certificate Management of Horses

Full-time: 1 year

Shuttleworth College

Edexcel (BTEC) National Certificate Management of Horses

Full-time: 1 year – 5 days a week in college

National Diploma

This course has been designed to meet needs of employers within the horse industry. A two year programme for school leavers with a number of GCSEs or for mature returners, it aims to develop candidates technical competence and management skills.

Entry Requirements:

4 GCSEs C+ (English and Maths)

First Diploma

National Certificate

NVQ Level 2

Relevant industrial background

Age:

16 years +

Must be:

Some previous equine experience

Areas of study may include

- Horse husbandry
- Equitation
- Nutrition and fitness
- Breeding stock
- Equine science
- Business management

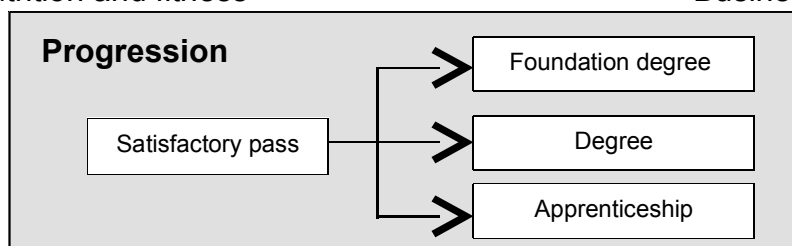

Participating Institutions

Easton College

**Edexcel (BTEC)
National Diploma
Management of
Horses**
Full-time: 2 years – 4
days a week in college
Work experience: 1
day a week

The College of West Anglia

**Edexcel (BTEC)
National Diploma
Horse Studies**
Full-time: 2 years – 5
days a week in college
Work experience: 6
months students may
be allocated occasional
yard duties
Venue: Milton and
Wisbech

Writtle College

**Edexcel (BTEC)
National Diploma
Horse Studies**
Full-time: 2 years – 5
days a week in college
Work experience:
400 hours at work
placement of the
students' choice in
addition to yard duties
at college

Shuttleworth College

**Edexcel (BTEC)
National Diploma
Equine Studies**
Full-time: 2 to 3 years
– 5 days a week in
college
Work experience: 1
year if student has no
adequate previous
experience

Otley College

Edexcel (BTEC) Horse Management
Full-time: 2 years

NVQ Level 3

The NVQ Level 3 is aimed at those already employed within the industry at a supervisory level, who wish to gain a recognised work-based qualification. This is a part-time course assessed by observation of practical activities and a portfolio of evidence.

Entry Requirements:
 NVQ Level 2
 Relevant industrial experience
Age:
 16 years +
Must be:
 Employed within the industry

Areas of study may include

- Resolving health and condition problems
- Monitoring routine health care
- Contribution to the training and development of teams
- Transporting horses

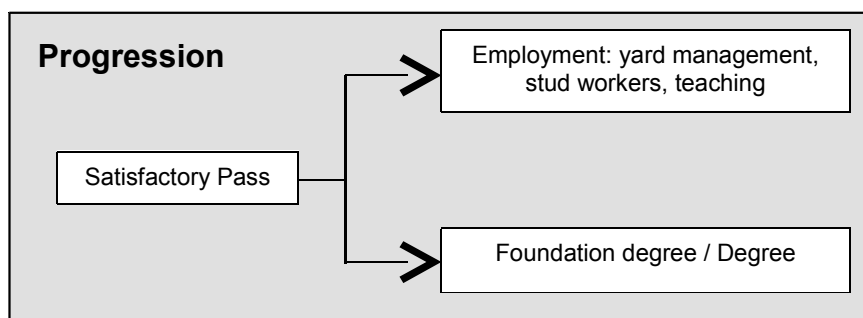

Participating institutions

<p>Otley College</p> <p>NVQ Level 3 Horse Care and Management* Part-time: 2 years – 1 day a week in college</p> <p>National Award Horse Management Full-time: 1 year Part-time: 2 years</p>	<p>Easton College</p> <p>NVQ Level 3 Horse Care and Management* Part-time: 1 year – 1 day a week</p>	<p>The College Of West Anglia</p> <p>NVQ Level 3 Horse Care and Management* Part-time: 1 year Venue: Wisbech and Milton</p>	<p>Writtle College</p> <p>NVQ Level 3 Horse Care and Management* Part-time: 1 to 2 years – flexible attendance</p>
<p>Shuttleworth College</p> <p>NVQ Level 3 Horse Care and Management* Part-time: Flexible</p>			

** Also available as an Apprenticeship*

Choosing a Higher Education Course in Horse Studies

Foundation degree

This course is designed for students who plan to work in the equine industry in a 'hands-on' manner, having a strong emphasis on applied horse handling skills in either a stud or equitation-based environment. It will offer the chance to combine the scientific, technical and commercial aspects of horse management with the development of sound practical equine skills.

Entry Requirements:

40 UCAS tariff points

A maximum of 20 tariff points will be counted from Key Skills

Mature students with some formal qualifications but with experience of agriculture are encouraged to apply

Age:

18 years +

Must be:

Interested in a career within the industry

Areas of study may include

- Stud practical skills
- Applied reproduction and stud management
- Grassland science and production
- Exercise physiology
- Equine reproductive physiology
- Introduction to management
- Event management
- Youngstock production

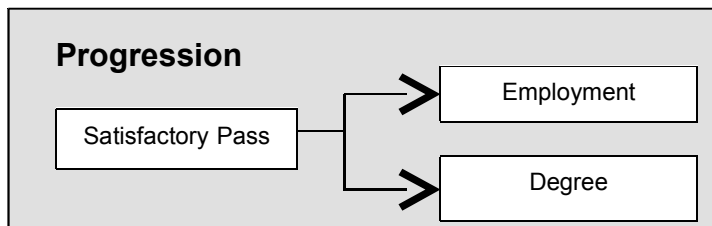

Participating institutions

Otley College

FdA Equine Studies

Part-time: 3 or more years

Distant Learning

Easton College

Currently HNC/HND programmes on offer but will change to Foundation degrees from Sept 2006, full and part-time.

Writtle College

FdSc Equine Studies

UCAS Code: D429

Full-time: 2 years

Part-time: 4 or more years

FdSc Equine Science

UCAS Code: D428

Full-time: 2 years

Part-time: 4 or more years

FdSc Equine Breeding and Stud Management

UCAS Code: DN4F

Full-time: 2 years

Part-time: 4 or more years

FdSc Equine Studies and Business Management

UCAS Code: DN4G

Full-time: 2 years

Part-time: 4 or more years

Honours degree

Degree level courses are aimed at developing vocational and academic skills within the equine sector. Students will be trained to apply scientific and / or business principles to their specialist area, while having the opportunity to gain broader skills within the industry.

Entry Requirements:

A levels
National Diploma / Certificate relevant subject
NVQ Level 3 Horse Care
Foundation degree
Mature entry

Age:

18 years +

Must be:

Interested in a career within the industry

Areas of study may include

- Equine practical skills
- Marketing and personnel
- Economics
- Applied equine technology
- Equine health management
- Behaviour
- Grassland science and production
- Strategic management

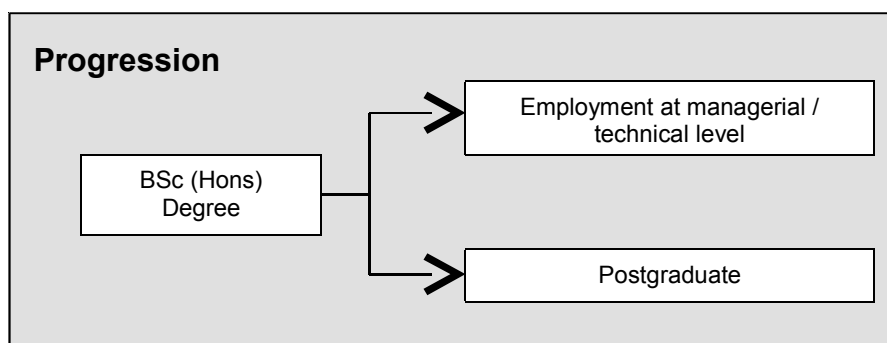

Participating institutions

Writtle College

BSc (Hons) Equine Studies

UCAS code: D334

Full-time: 3 years

BSc (Hons) Equine Studies and Business Management

UCAS code: D323

Full-time: 3 years

BSc (Hons) Equine Breeding and Stud Management

UCAS code: D426

Full-time: 3 years

BSc (Hons) Equine Science

UCAS code: DNL2

Full-time: 3 years

Part-time study also available

Short Courses

There are a number of other horse-related courses held in East Anglia. These range from an introduction to caring for horses to specialised, advanced courses. A number are BHS validated.

Formal qualifications are not usually required, though some of the more advanced courses may expect students to have some previous practical experience. Individuals will be expected to purchase their own materials for the practical lessons and should enquire as to cost and availability prior to joining a course.

Please note that institutions may change or cancel courses if necessary and other colleges and organisations, not included, may also run courses locally.

Participating institutions

The College of West Anglia

The College holds short courses in areas such as:
BHS Riding and Road Safety
BHS Horse Knowledge, Care and Riding Stages 1 and 2

Writtle College

The College holds short courses in areas such as:
BHS Horse Owners' Certificate
BHS Stage 1 and 2 Horse Knowledge and Care
BHS Stage 1 and 2 Revision Day

Easton College

The College holds short courses in areas such as:
BHS Stage 1 and 2 Training
BHS Stage 3 and PTT

Otley College

The College holds short courses in areas such as:
BHS Horse Knowledge and Riding Stages 1 & 2
BHS Horse Knowledge Stage 3
BHS Preliminary Teaching

Shuttleworth College

The College holds short courses in areas such as:
BHS Stage 1, 2 and 3 Horse Knowledge and Care

Horticulture

Introduction

Contrary to popular belief, horticulture is much more than just gardening. In reality it is a broad term which covers all aspects of the production of flowers, plants and crops to sell (Commercial Horticulture) and the care and development of land such as parks, garden and woods, for pleasure and recreation purposes. (Amenity Horticulture).

The horticulture industry is one of the UK's major employment sectors with a range of careers available at all levels, from the hands-on practical side, to the high tech area of commercial growing, supply chains and logistics needed to store and deliver produce to supermarkets. There are more paid openings available within the industry as a whole at the present time, than there are qualified employees to fill them. This is especially true at the higher levels, with opportunities for careers existing both locally and abroad.

Potential students need patience, dedication and an interest in plants. A relative degree of physical fitness and willingness to work outside is required by many of the FE courses as at this level. The courses offer knowledge and skills training generally aimed at the practical side of the industry.

Commercial Horticulture

This sector incorporates fruit, vegetable and protected crop growing, nursery and tree production as well as cut flowers and bedding plants. Through a mixture of theory and practical sessions the courses cover scientific methods, production and retail skills, such as marketing and sales. There are opportunities to specialise in particular areas, such as organic production, a particular growth industry, in which both beginners and conversion courses are available.

Amenity Horticulture

Landscape and Garden Management, Design and Construction

This sector includes the design, management and construction of theme parks, shopping malls, residential and business parks, as well as private, public and historic gardens, parks and natural habitats. Students look at the balance between development and sustainability, covering both the practical and technical aspects of landscaping and using the latest research and technology.

Sports Turf Management

This involves the care and management of fine turf and winter play pitches for sport and leisure activities such as bowls, tennis, football and golf. Courses cover the principles of design, management, pest control and mechanisation.

Arboriculture and Forestry

This sector involves much more than just tree surgery, but also the complete management of trees, forests and woodlands, from health and safety and climbing skills, to felling, planting and tree care. This is a relatively small industry within the UK but there are overseas opportunities in countries such as the USA and Canada.

There are various leisure gardening courses available suitable for beginners through to keen amateurs. These can lead to further formal qualifications.

Further Education

Qualification	Level	Course Title	Page
Foundation	Entry	<ul style="list-style-type: none"> • Horticulture • Skills for Life 	95
NVQ Level 1	1	<ul style="list-style-type: none"> • Amenity / Commercial Horticulture • Land-based operations 	96
City and Guilds	2	<ul style="list-style-type: none"> • Arboriculture 	97
First Diploma	2	<ul style="list-style-type: none"> • Horticulture 	98
NVQ Level 2	2	<ul style="list-style-type: none"> • Horticulture • Forestry – Establishment and Maintenance - Harvesting • Arboriculture • Sports Turf • Hard Landscaping • Green Keeping – Sports Turf Management • Turf Management and Maintenance 	99
C&G National Certificate	2	<ul style="list-style-type: none"> • Arboriculture • Horticulture • Organic Horticulture • Garden Design 	100
NVQ Level 3	3	<ul style="list-style-type: none"> • Amenity / Commercial Horticulture • Landscape and Garden Design • Sports Turf 	101
National Diploma	3	<ul style="list-style-type: none"> • Amenity Horticulture • Horticulture (with options) 	102

Higher Education

Qualification	Course Title	Page
Foundation degree (replacing HND/HNC)	<ul style="list-style-type: none"> • FdSc Horticulture • FdSc Horticulture (Landscape and Amenity Management) • FdA Landscape Construction • FdSc Sports Turf and Golf Course Management 	103
Degree	<ul style="list-style-type: none"> • BSc (Hons) Horticulture • BSc (Hons) Landscape and Amenity Management • BSc (Hons) Horticulture with Business Management • BSc (Hons) Sports Turf Science and Management • BSc (Hons) Horticulture Crop Production • BSc (Hons) International Horticulture 	104

Miscellaneous

Short and Leisure Courses	Page
<ul style="list-style-type: none"> • Leisure Gardening 	105
<ul style="list-style-type: none"> • Royal Horticulture Society Awards 	-
<ul style="list-style-type: none"> • NPTC 	107

Linking subjects

A **horticulture** course can allow progression into other areas

Course
<ul style="list-style-type: none"> • Agriculture • Conservation • Land-Related Engineering

Choosing a Further Education Course in Horticulture

Foundation Level

Aimed at those with little or no formal qualifications. This is an introduction to working within the horticulture industry, while continuing to develop basic educational skills.

A high level of student support is given and students are instructed in communication, numeracy and life skills.

Entry Requirements:

No formal qualifications are needed

Age:

16 years +

Must be:

Interested in the subject area

Areas of study may include

- Amenity horticulture
- Commercial horticulture
- Growing plants under glass
- Plant care and maintenance
- Landscaping / propagation methods
- Gardening/planning conservation
- Horticulture machinery

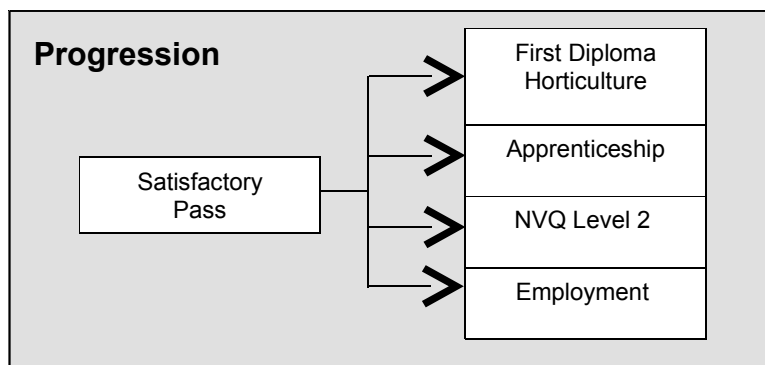

Participating institutions

Easton College

Edexcel Certificate Skills for Working Life

Full-time: 1 year – 4 days a week in college

Otley College

Foundation Horticulture. College Foundation Programme Access Horticulture

Full-Time: 1 or 2 years – 4 days a week in college

Work experience: 1 day a week in college based or industrial placement

NVQ Level 1

This course provides students with a basic knowledge in horticulture and assists them in acquiring practical skills in general aspects of the horticulture industry.

Entry Requirements:

No formal qualifications are required

Age:

16 years +

Must be:

Interested in a career within horticulture

Areas of study may include

- Establishing and maintaining plants
- Maintenance and landscape features
- Preparation of sports surfaces
- Soil and plant nutrition
- Tree and shrub planting
- Basic turf establishment and care
- Plant care / identification
- Machinery maintenance and operation
- Basic hard landscape works

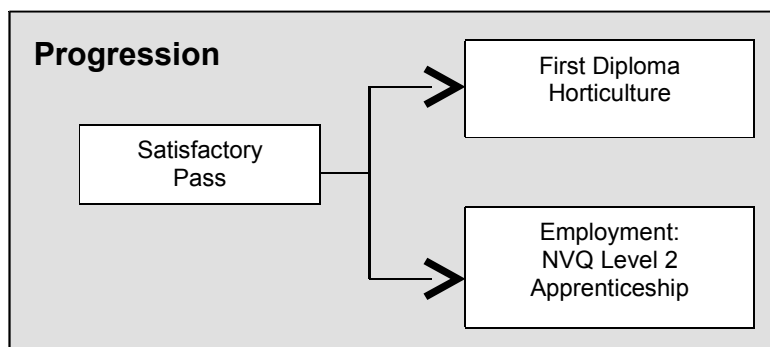

Participating institutions

Easton College

NVQ Level 1 Land-based Operations

Full-time: 1 year – 4 days a week in college

Work experience: included

The College of West Anglia

NVQ Level 1

Amenity / Commercial Horticulture

Part-time: 1 year – 1 day a week in college

City and Guilds Phase 2

This range of courses is generally aimed at mature students with some basic knowledge of amenity horticulture, who wish to gain a formal qualification, but cannot study on a full-time basis.

Entry Requirements:

GCSE English, Maths and Science preferred

Age:

16 years +

Must be:

Physically fit and have a head for heights

Areas of study may include

- Trees and shrubs
- Trees and the law
- Pests
- Diseases and disorders
- Tree climbing
- Chainsaw operation
- Tree pruning
- Tree surgery
- Tree felling and extraction
- Health and safety
- Arboriculture machinery and hand tools
- Propagation and care of ornamental trees

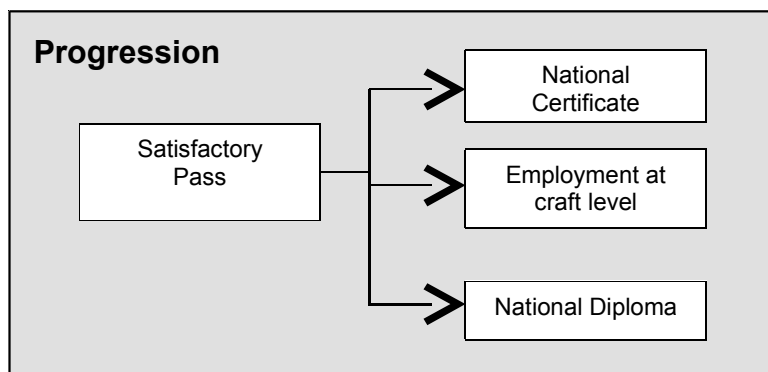

Participating institutions

Writtle College

**City and Guilds
Phase 2**

Arboriculture

Part-time: 1 year –
1 day a week in
college

First Diploma

Aimed at school leavers with some qualifications, or mature returners who wish to work within the horticultural industry with some supervision. Designed as a basic introduction to horticulture, the courses cover a number of fundamental disciplines in both practical and theoretical sessions.

Entry Requirements:

Studied to GCSE level
 Foundation in Land-Based Industries
 NVQ Level 1
 Mature entry
 Previous relevant experience

Age:

16 years +

Must be:

Committed and interested in horticulture

Areas of study may include

- Science and technology
- Plant uses and identification
- Site assessment / machinery
- Marketing and planning
- Personal finance

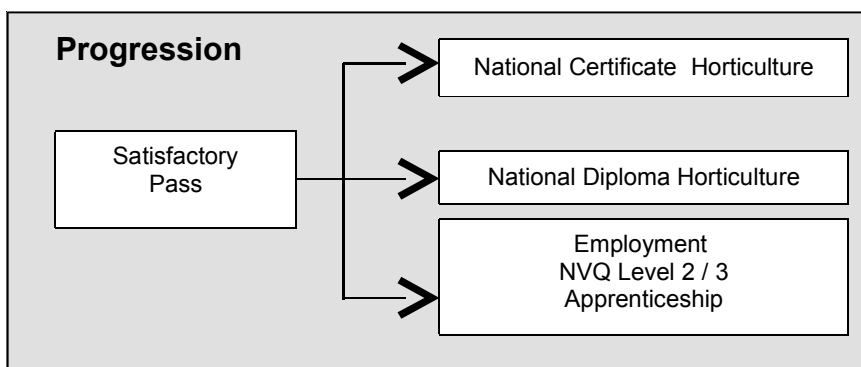

Participating institutions

<p><u>Easton College</u></p> <p>Edexcel (BTEC) First Diploma Horticulture Full-time: 1 year – 4 days a week in college Work experience: 1 day a week</p>	<p><u>The College of West Anglia</u></p> <p>Edexcel (BTEC) First Diploma Horticulture Full-time: 1 year – 4 days a week in college Work experience: 1 day a week Venue: Wisbech or Milton</p>	<p><u>Writtle College</u></p> <p>Edexcel (BTEC) First Diploma Horticulture Full-time: 1 year – 4 days a week in college Work experience: 1 day a week</p>	<p><u>Shuttleworth College</u></p> <p>Edexcel (BTEC) First Diploma Horticulture Full-time: 1 year – 4 days a week in college Work experience: 1 day a week</p>
--	---	---	--

NVQ Level 2

The NVQ Level 2 is aimed at students with some basic experience in horticulture who want to gain a work-based qualification and expand their knowledge. Students will usually be employed within the industry or take part in relevant voluntary work.

Entry Requirements:

No formal qualifications are required but students need a good standard of education

Age:

16 years +

Must be:

Employed or have a suitable work placement within the industry

Areas of study may include

- Plant identification / botany
- Plant / turf establishment and maintenance
- Preparing sites for planting crops
- Horticulture mechanisation
- Plant pests and diseases
- Health and safety

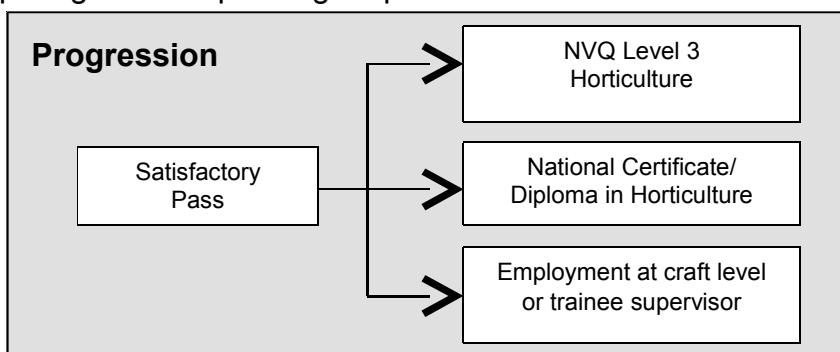

Participating institutions

<p><u>Otley College</u></p> <p>NVQ Level 2 Amenity Horticulture* Part-time: 1 year – 1 day a week in college</p> <p>NVQ Level 2 Amenity Horticulture – Sports Turf Maintenance Part-time: 1 year – 1 day a week in college</p> <p>NVQ Level 2 – Production Horticulture Part-time: 1 year – 1 day a week in college</p>	<p><u>Easton College</u></p> <p>NVQ Level 2 Horticulture Part-time: 1 year plus – 1 day a week in college</p> <p>Optional pathways available in Decorative Horticulture, Nursey Stock, Hard Landscaping and Sports Turf.</p>	<p><u>The College of West Anglia</u></p> <p>NVQ Level 2 Amenity Horticulture* Part-time: 1 year</p> <p>NVQ Level 2 Green Keeping / Sports Turf Management Part-time: 2 years</p> <p>NVQ Level 2 Sports Turf Management / Maintenance Part-time: 2 years</p>	<p><u>Writtle College</u></p> <p>NVQ Level 2 Amenity Horticulture Part-time: 1 year</p> <p>NVQ Level 2 Forestry – Establishment and Maintenance Part-time: 1 year</p> <p>NVQ Level 2 Forestry – Harvesting Part-time: 1 year</p> <p>NVQ Level 2 Sports Turf* Part-time: 1 year</p>
<p><u>Shuttleworth College</u></p> <p>NVQ Level 2 Arboriculture*</p> <p>NVQ Level 2 Sports Turf*</p> <p>NVQ Level 2 Decorative Horticulture*</p> <p>NVQ Level 2 Hard Landscaping* Part-time: 1 year – 1 day a week in college</p>			

* Also available as an Apprenticeship

National Certificate

This level of course aims to provide students with the relevant technical knowledge and practical skills needed within the horticulture industry.

Entry Requirements:

NVQ Level 2
GCSEs
First Diploma
RHS General Certificate
Mature entry

Age:

17 years + (C&G)

Must be:

Interested in the subject area

Areas of study may include

- Estate skills / records and supervision
- Horticulture machinery studies
- Plant and soil science
- Plant identification
- Pests and diseases
- Nursery practice
- Basic engineering principles

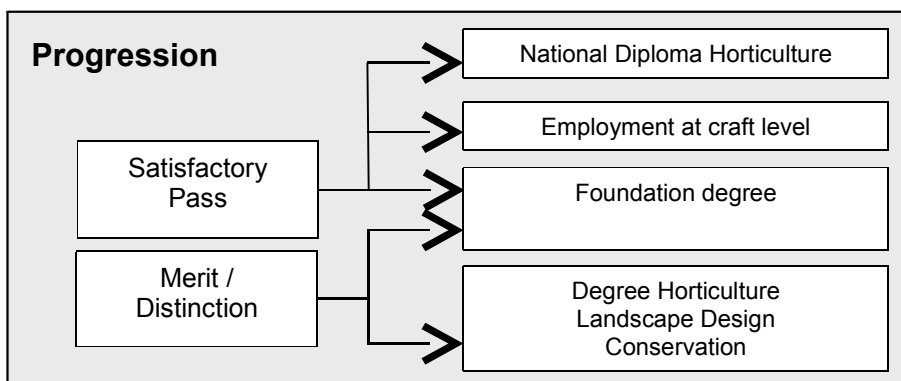

Participating institutions

Easton College

**Exdexcel (BTEC)
National Award Organic
Horticulture**

Part-time: 1 year – 1 day
a week in college

Shuttleworth College

**C&G National Certificate
Garden Design**

Full-time: 1 year
Part-time: 2 years

**C&G National Certificate
Horticulture**

Full-time: 1 to 2 years – 4
days a week in college

**C&G National Certificate
in Arboriculture**

Full-time: 1 year – 5 days a
week in college

NVQ Level 3

The NVQ Level 3 is aimed at those already employed within the horticulture industry at a supervisory / managerial level, who wish to gain a recognised work-based qualification. This is usually a part-time course, assessed by observation and practical activities and a portfolio of evidence.

Entry Requirements:

NVQ Level 2 Amenity Horticulture
Relevant work experience
National Certificate Horticulture
First Diploma

Age:

16 years +

Must be:

Employed within the industry at a supervisory level

Areas of study may include

- Sports turf
- Hard landscaping
- Nursery stock
- Decorative horticulture
- Construction and restoration
- Botany / plant identification
- Fencing / patio and paving
- Machinery and equipment

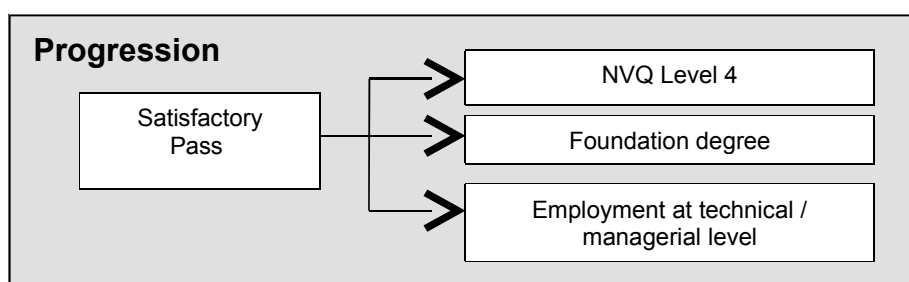

Participating institutions

<p>Easton College</p> <p>NVQ Level 3 Horticulture Part-time: 1 year + - 1 day a week in college</p> <p>Optional pathways available in Decorative Horticulture, Nursery Stock, Hard Landscaping and Sports Turf.</p>	<p>Otley College</p> <p>NVQ Level 3 -Amenity Horticulture Production - Amenity Horticulture – Sports Turf Maintenance Part-time: 1 year – 1 day a week in college All Apprenticeships</p>	<p>Writtle College</p> <p>NVQ Level 3 -Amenity Horticulture* -Commercial Horticulture -Retail Operations – Commercial Horticulture -Forestry or Arboriculture -Sports Turf Maintenance* Part-time: 2 years</p>	<p>Shuttleworth</p> <p>NVQ Level 3 -Sports Turf* -Decorative Horticulture* -Hard Landscaping* -Commercial Horticulture* -Sports Turf* Part-time: 2 years – flexible</p>
	<p>The College of West Anglia</p> <p>NVQ Level 3 Sports Turf Maintenance* Part-time: 2 years - flexible</p>		

* Also available as an Apprenticeship

National Diploma

The National Diploma is designed to provide practical training and experience in horticultural practice and technology to equip students with the necessary skills and knowledge to gain employment in the industry at craft and supervisory levels. It is also a sound basis for those candidates wishing to run their own horticulture business.

Entry Requirements:

4 GCSEs grade C+
 First Diploma
 NVQ Level 2 Horticulture
 National Certificate Horticulture
 Mature Entry

Age:

16 years +

Must be:

Committed / interested in horticulture

Areas of study may include

- Plant and soil science
- Horticulture skills and plant knowledge
- Landscape skills / machinery operations
- Business management
- Basic engineering principles
- Turf production and management

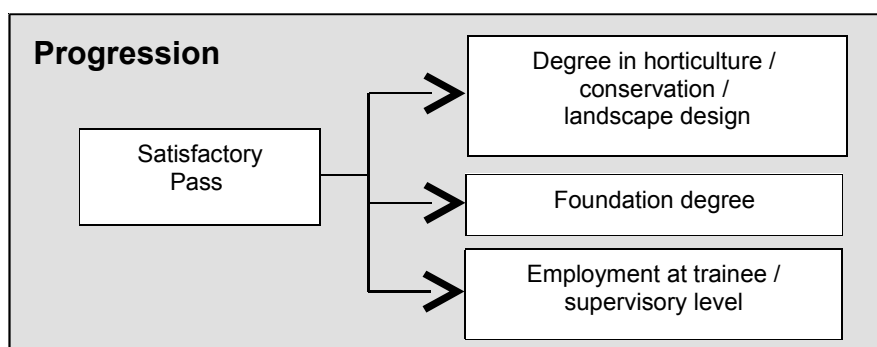

Participating institutions

<p><u>Easton College</u></p> <p>Edexcel (BTEC) National Diploma Amenity Horticulture Full-time: 2 years – 4 days a week in college Work experience: 1 day a week</p>	<p><u>Shuttleworth College</u></p> <p>Edexcel (BTEC) National Diploma Amenity Horticulture Full-time: 2 years – 4 days a week in college Work experience: 2 x 5 weeks</p>	<p><u>The College Of West Anglia</u></p> <p>Edexcel (BTEC) National Diploma Horticulture Full-time: 2 years Work experience: 2 x 5 weeks</p>	<p><u>Writtle College</u></p> <p>Edexcel (BTEC) National Diploma Horticulture Full-time: 3 years – 5 days a week Work experience: 1 year paid employment</p>
--	---	--	---

Choosing a Higher Education Course in Horticulture

Foundation degree

This course allows students to follow a general horticultural qualification by choosing areas of study from across the entire horticultural programme. This makes it ideal for students who may be unclear about which sector of the horticultural industry they want to work in.

Entry Requirements:

40 UCAS tariff points

A maximum of 20 tariff points will be counted from Key Skills

Mature students with some formal qualifications but with experience of agriculture are encouraged to apply

Age:

18 years +

Must be:

Interested in horticulture

Areas of study may include

- Horticultural science
- Interior landscaping
- Golf course design & management
- Tropical horticulture
- Product development & packaging

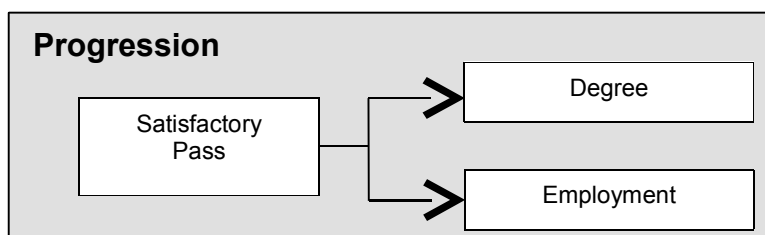

Participating institutions

Writtle College

FdSc Horticulture

Full-time: 2 years
Part-time: 4 years +
UCAS Code: D419

FdSc Horticulture (Landscape and Amenity Management)

Full-time: 2 years
Part-time: 4 years +
UCAS Code: KNH2

FdSc Sports Turf and Golf Course Management

Full-time: 2 years
Part-time: 4 years +
UCAS Code: N290

FdSc Landscape Construction

Full-time: 2 years – 1 day a week in college
Part-time: 4 years +
UCAS Code: K300

FdSc Horticulture Crop Production

Full-time: 2 years
Part-time: 4 years +
UCAS Code: D415

FdSc Horticulture (Nursery and Retail)

Full-time: 2 years
Part-time: 4 years +
UCAS Code: D404

Easton College

Currently HNC/HND programmes on offer but will change to Foundation degrees from Sept 2006, full and part time.

Honours degree

This degree level course is aimed at developing vocational, technical and managerial skills within the horticultural sector. Students will learn to apply business knowledge and scientific principles to their specialist area, while having the opportunity to gain broader skills within the industry.

Entry Requirements:

A levels
National Certificate
National Diploma
GNVQ Advanced
Foundation degree
Relevant industrial experience
Mature entry

Age:

18 years +

Must be:

Enthusiastic and interested in the subject area

Areas of study may include

- Research techniques / art and design
- Landscape and garden design
- Plants for landscape and garden design
- Landscape science and engineering
- Business skills and contract management

Progression

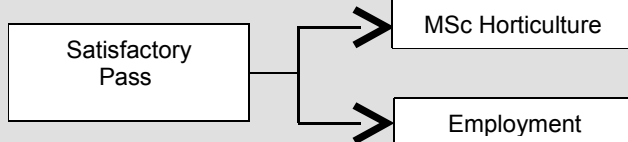

Participating institutions

Writtle College

BSc (Hons) Horticulture

UCAS code: D410 Full-time: 3 years

BSc (Hons) Horticulture with Business Management

UCAS code: DN42 Full-time: 3 years

BSc (Hons) Landscape and Amenity Management

UCAS code: D455 Full-time: 3 years

BSc (Hons) Sports Turf Science and Management

UCAS code: DNK2 Full-time: 3 years

BSc (Hons) Horticultural Crop Production

UCAS code: D451 Full-time: 3 years

BSc (Hons) International Horticulture

UCAS code: D452 Full-time: 3 years

Part-time study also available

Short Courses

A number of colleges run short courses within horticulture. These are stand-alone courses, which can lead to further qualifications.

Please note that these courses may be subject to change at any time.

Formal qualifications are not usually required, though some of the more advanced courses may expect students to have some previous practical experience.

Participating institutions

Easton College

RHS Taster sessions run throughout the year
Level 1 Horticultural Skills Test

Otley College

Courses in Horticulture are available as part of the leisure learning programme.

The College of West Anglia

Runs garden design courses.

Writtle College

Holds a number of short courses and RHS presentations throughout the year, including CAD, Garden Design, Landscaping Skills, and the Horticulture Trades Association – Retail Plant Care Award.

Royal Horticultural Society Awards

The RHS examinations have been recognised as industrial qualifications for more than a century. Aimed at students already working within the horticulture industry, the levels range from the general, obtainable by keen amateurs, to the masters, which can be only undertaken by those with the necessary professional experience. The participating institutions cover the RHS syllabus, but the students need to apply to the RHS to sit the examinations at a local centre.

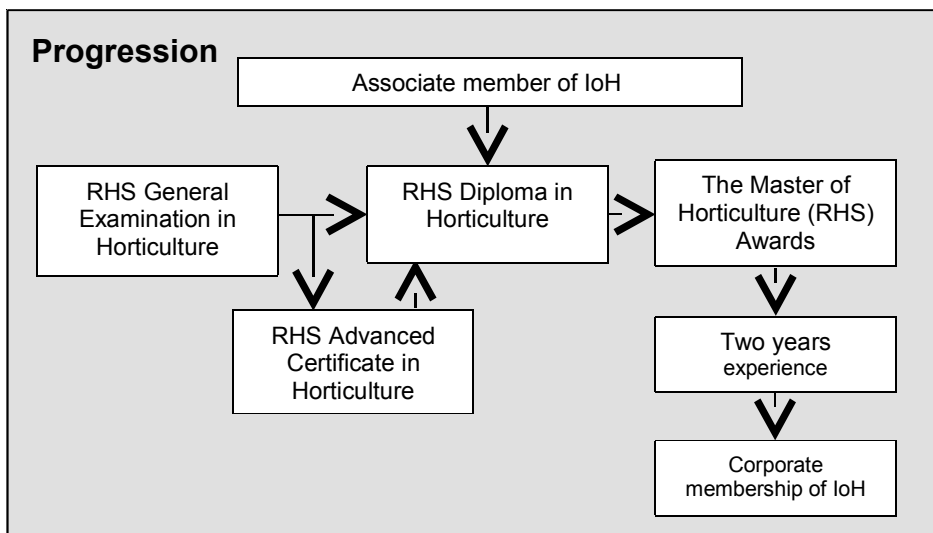

Participating institutions

<p><u>Easton College</u></p> <p>RHS Certificate Horticulture Part-time: 1 year – 1 day or evening a week in college</p> <p>RHS Advanced Certificate Horticulture Part-time: 2 years – 1 evening a week in college.</p>	<p><u>Otley College</u></p> <p>RHS General Certificate in Horticulture Part-time: 20 weeks – 1 evening a week and some weekends</p> <p>RHS Advanced Certificate in Horticulture Part-time: 1 year – 1 evening a week in college and some weekends</p>	<p><u>The College Of West Anglia</u></p> <p>RHS Certificate Horticulture Level 2 Part-time: 1 evening a week in college</p> <p>RHS Certificate Horticulture Level 2 Part-time: 1 evening a week in college</p>	<p><u>Writtle College</u></p> <p>RHS General Horticulture Part-time: 2 years – 1 evening a week</p> <p>RHS Advanced Certificate Part-time: 1 year – 1 evening a week in college</p> <p>RHS Diploma Part-time: 2 years – 1 day / evening a week</p>
		<p><u>Shuttleworth College</u></p> <p>RHS General Certificate in Horticulture Part-time: 5 terms – 1 evening a week in college (1 year fast track option)</p> <p>RHS Intermediate Certificate Part-time: 2 years – 1 day / evening a week</p>	

Royal Forestry Society (RFS) / National Proficiency Test Council (NPTC) and Forestry and Arboriculture Safety and Training Council (FASTCO) Awards

There are a number of short awards by the NPTC and FASTCO in countryside skills within the amenity horticulture sector such as tree climbing, chainsaw use and tree felling. These may be available as separate units or a certificate, such as the NPTC Basic Certificate of Competence, which is the standard in forestry and landscape maintenance industries.

The RFS Certificate in Arboriculture covers a wide range of theoretical and practical knowledge of trees and woodland management. The RFS Professional Diploma in Arboriculture is a top qualification for the professional who is working with high value trees. It is exceedingly hard to achieve and is not to be attempted by the amateur or countryman who has only passing knowledge of trees.

Areas of study may include

- Tree and shrub knowledge
- Nursery practices / tree establishment
- The tree's environment
- Woodland and urban forestry
- Pests and diseases of woody plants
- Biology / maintenance of woody plants
- Legislation and arboriculture
- Organisations and finance

Participating institutions

<p><u>Easton College</u></p> <p>Chainsaw Certificate Brushcutter / Clearing Saw Chainsaw Maintenance and Safe Use</p> <p>A number of separate NPTC units are also available in such areas as tree felling, clearing crosscutting and stacking, tree climbing, pruning and dismantling</p>	<p><u>College of West Anglia</u></p> <p>Holds short courses in chainsaw maintenance and use</p>	<p><u>Writtle College</u></p> <p>Holds short courses in chainsaw maintenance and use, tree climbing and dismantling</p>
--	---	---

Land – Related Engineering

Introduction

Engineering within the land-based sector is split into the two areas of **Service Engineering** and **Agricultural Engineering**. Service engineering is available at a further education level, while agricultural engineering is a higher educational discipline.

Land-related Service Engineering

The agricultural and horticultural industries rely on high cost, technically advanced machinery and equipment. This means that qualified service engineers, with a sound knowledge of basic engineering techniques, are needed to carry out services and maintenance on equipment ranging from combine harvesters to lawnmowers. At the present time there are a shortage of service engineers to satisfy customer demand, there are more positions available throughout the country than trained employees to fill them.

Courses in service engineering allow students to gain technical skills through both practical experience in the workshops and theory sessions in the laboratories, using a wide range of equipment. The workshops hold a large selection of machinery and are run on the lines of a commercial business, insuring direct access to employment.

Agricultural Engineering

Agricultural engineering is the appliance of scientific and technical engineering systems to the land. The advanced agricultural practice within the developed world require a high level of mechanisation and the use of the latest technological advances, from production to harvesting, storage and transportation. Within other areas of the world, agricultural engineering can contribute to developing food production techniques within a sustainable environment. The discipline is not confined to agriculture, but is involved with all forms of land use such as the environment, leisure and recreation.

Further Education

Qualification	Level	Course Title	Page
First Diploma	2	<ul style="list-style-type: none"> • Agriculture (Mechanisation) • Agriculture and Horticulture Machinery 	110
NVQ Level 2	2	<ul style="list-style-type: none"> • Agricultural Machinery Service Engineering • Groundcare Machinery Service Engineering • Retail Operations (Mechanisation) • Service Engineering • Land-Based Service Engineering • Performance Engineering Operations • Performance Manufacturing Operations • Service Engineering Agriculture and Groundcare Engineering 	111
NVQ Level 3	3	<ul style="list-style-type: none"> • Service Engineering • Agricultural Machinery Service Engineering • Groundcare Machinery Service Engineering 	112
National Diploma	3	<ul style="list-style-type: none"> • Land-based Technology 	113

Miscellaneous

Short and Leisure Courses	Page
<ul style="list-style-type: none"> • Chainsaws, Pesticides, Machinery and Equipment • CITB Plant Maintenance • CITB Specialist Plant and Machinery Operations 	114

Linking subjects

Engineering courses can allow progression into other subject areas.

Course
<ul style="list-style-type: none"> • Agriculture • Conservation • Horticulture

Choosing a Further Education Course in Land-related Engineering

First Diploma

This is an introductory course for those wishing to undertake a career within the service engineering sector and is suitable for both school leavers and mature students wanting to retrain. Candidates are given a basic grounding in the construction, operation and maintenance of a range of agricultural and groundcare machinery.

Entry Requirements:

GCSE English, Maths and Science

Age:

16 years +

Must be:

Interested in the subject area

Areas of study include

- Tractors – construction, operation, use and maintenance
- Agricultural machinery
- Horticultural machinery
- Workshop – tools, equipment, fabrication, welding and maintenance and repair.

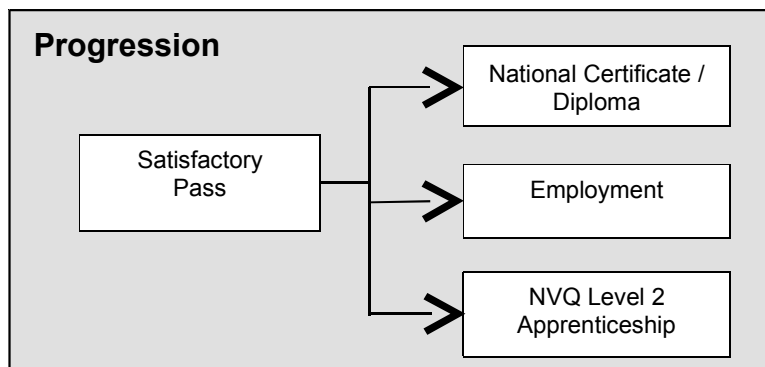

Participating institutions

Writtle College

Edexcel (BTEC) First Diploma in Agriculture (Mechanisation)
Full-time: 1 year – 4 days a week in college
Work experience: 6 weeks

Shuttleworth College

Edexcel (BTEC) First Diploma Agriculture (Mechanisation)
Full-time: 1 year – 4 days a week in college
Work experience: 1 day a week

NVQ Level 2

The NVQ Level 2 is a work-based programme aimed at developing candidates' skills in agricultural or groundcare machinery engineering. By the end of the programme students should be able to work effectively under supervision and have a basic underpinning knowledge of systems and machines.

Entry Requirements:

No formal qualifications are required

Age:

16 years +

Must be:

Employed or have a suitable work placement within the industry

Areas of study may include

- Reinstallation of work area
- Production of engineering products
- Machinery dismantling and rebuilding
- Machinery performance
- Health and safety / working relationship
- Restoration of garden machinery
- Bending and shaping of materials / welding

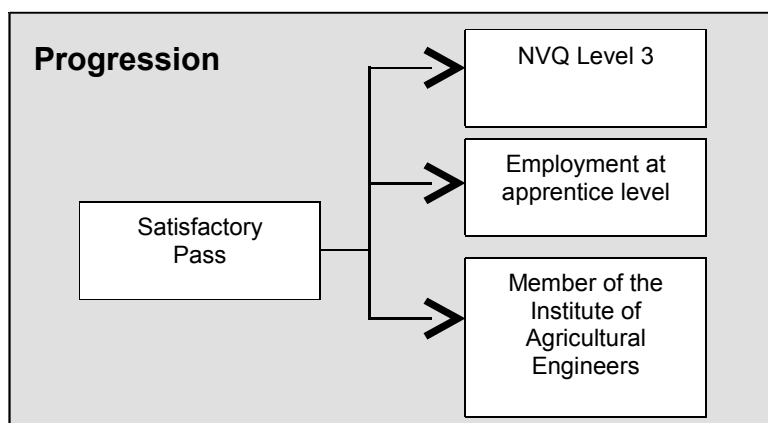

Participating institutions

<p><u>Shuttleworth College</u></p> <p>NVQ Level 2 Service Engineering (Agriculture and Groundcare Machinery) Part-time: 2 years</p>	<p><u>Writtle College</u></p> <p>NVQ Level 2 Service Engineering Agricultural and Groundcare Engineering*</p> <p>NVQ Level 2 Retail Operations (Mechanisation)</p>	<p><u>Easton College</u></p> <p>NVQ Level 2 Agricultural / Groundcare Machinery Service Engineering* Part-time: 2 years</p>	<p><u>Otley College</u></p> <p>NVQ Level 2 Land-based Service Engineering * Performance Engineering Operations* Performing Manufacturing Operations * Part-time: 1 to 2 years</p>
--	---	--	--

* Also available as an Apprenticeship

NVQ Level 3

The programme aims to develop candidates' practical skills and underpinning knowledge of all systems and machines in agricultural or groundcare machinery service engineering. Focus is given to developing students testing and diagnostic skills as well as their managerial and supervisory abilities.

Entry Requirements:

NVQ Level 2 Machinery Service Engineering
Previous relevant experience

Age:

16 years +

Must be:

Employed within the agricultural or groundcare industries

Areas of study may include

- Fault diagnosis in machinery
- Establishment of customer technical requirements
- Testing, dismantling and re-assembling machinery under complex conditions
- Health and safety
- Determining resources to achieve objectives
- Co-ordination of work activities

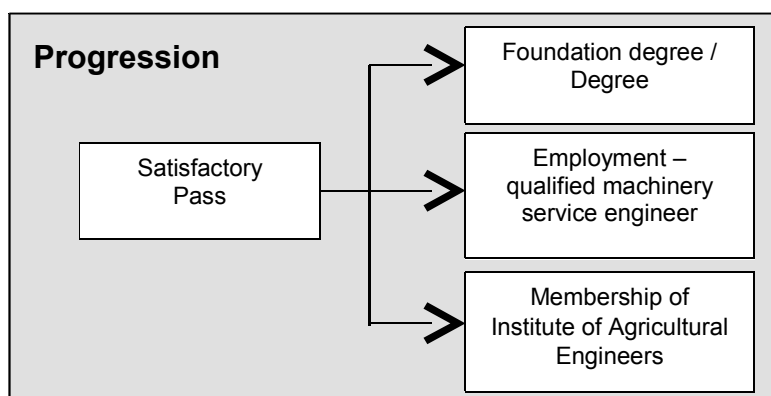

Participating institutions

Easton College

NVQ Level 3 Agriculture / Groundcare Machinery Service*
Part-time: 2 years – block release (9 x 2 week slots)

Otley College

NVQ Level 3 Land-based Service Engineering*
Part-time: 2 years – 1 day a week in college

Writtle College

NVQ Level 3 Service Engineering Agricultural and Groundcare Machinery*
Part-time: 2 years – 1 day a week in college

** Also available as an Apprenticeship.*

National Diploma

The National Diploma is designed to provide practical training and experience in engineering and technology to equip students with the necessary skills and knowledge to gain employment in the industry at craft and supervisory levels. It is also a sound basis for those candidates wishing to run their own business.

Entry Requirements:

4 GCSEs grade C+
First Diploma
NVQ Level 2 Engineering
Mature Entry

Age:

16 years +

Must be:

Committed / interested in engineering

Areas of study may include

- Fault diagnosis in machinery
- Health and safety
- Co-ordination of work activities
- Determining resources to achieve objectives
- Basic engineering principles

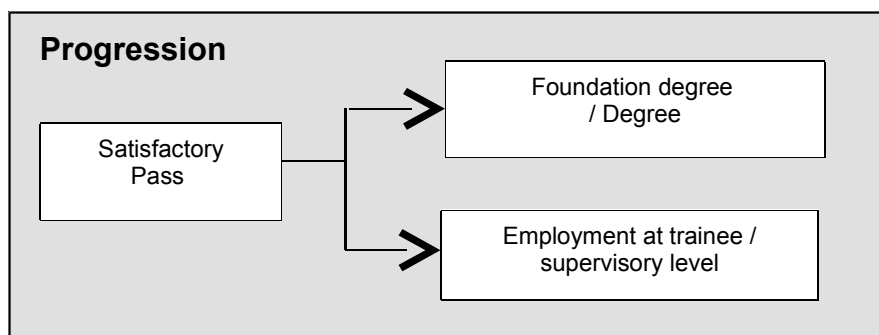

Participating institutions

Easton College

**Edexcel (BTEC)
National Diploma
Land-based
Technology
Full-time:** 2 years – 4
days a week in
college
Work experience: 1
day a week

Short Courses

A number of colleges run short courses within vehicles and machinery. These are stand-alone courses, which can lead to further qualifications.

Please not that these courses may be subject to change at any time.

Formal qualifications are not usually required, though some of the more advanced courses may expect students to have some previous practical experience.

Participating institutions

Otley College

CITB Plant Maintenance Level 1

Full-time: 1 year

CITB Specialist Plant and Machinery Operations Level 1

Full-time: 1 year

Writtle College

Courses in:

Abrasive Wheels

Basic / Advanced Welding

Pesticide Application

Chainsaw and felling of small trees

Climb trees and aerial tree rescue

Agricultural tractor operation

Forklift truck training

Brushcutter and trimmer

Hedge cutter

Pedestrian rotary and flail mower

Ride on rotary and flail mower

Ride on cylinder mower

Compact tractor

Horticultural machine induction

Engine diagnostic

Easton College

Courses in:

Abrasive wheels

Basic/Advanced Welding

Pesticide Application

Agricultural tractor operation

Forklift truck training

Brushcutter and trimmer

Sport, Leisure and Tourism

Introduction

Leisure is a thriving industry, because it includes anything that people choose to do in their free time, ranging from visiting tourist attractions, outdoor events and sporting facilities, to natural geographical resources and places of historical interest. Such dynamic businesses need skilled individuals to manage, administer, market, develop and promote the many different organisations which open their doors to the public.

Careers in sport are diverse and cover many sectors including professional sport, coaching, sport teaching, management and outdoor pursuits. Courses mix practical sessions with a theory base, covering such aspects as sports science and technique, business studies, facility management and customer services. Facilities include sports halls, gyms and outdoor recreational areas.

The sport, leisure and tourism sector is worth approximately £76 billion per year to the UK and continues to grow. A diverse range of business activities provide opportunities for people to indulge in a wide range of recreational pastimes.

In common with other areas of business activities, those working in the sport, leisure and tourism industries need to provide the customer with choice, service quality and value for money in what can be a very competitive market.

Further Education

Qualification	Level	Course Title	Page
NVQ Level 1	1	<ul style="list-style-type: none"> • Sport and Leisure Instructor Award 	117
C&G Progression Award	1, 2 & 3	<ul style="list-style-type: none"> • Sport, Leisure Management • Sport and Leisure 	118
First Diploma	2	<ul style="list-style-type: none"> • Sport 	119
NVQ Level 2	2	<ul style="list-style-type: none"> • Sport, Recreation and Leisure • Adventure Activity Leadership • Operations Services • Exercise and Fitness 	120
National Diploma	3	<ul style="list-style-type: none"> • Travel and Tourism • Sport (Fitness and Sport development), (Outdoor Education), (Performance Excellence) • Outdoor Activities • Sports Contributions 	121
NVQ Level 3	3	<ul style="list-style-type: none"> • Sport, Recreation and Leisure • Operations and Development • Outdoor Education and Development • Coaching, Teaching and Instructing 	122

Higher Education

Qualification	Course Title	Page
Foundation degree (replacing HND/HNC)	<ul style="list-style-type: none"> • FdSc Sport and Exercise Performance • FdA Adventure Tourism • FdA Outdoor Activities Management • FdA Leisure Management 	123
Honours degree	<ul style="list-style-type: none"> • BSc (Hons) Sports and Exercise Performance • BSc (Hons) Leisure Management • BA (Hons) Leisure Management with Sports Management • BA (Hons) Adventure Tourism 	124

Miscellaneous

Short and leisure courses	Page
<ul style="list-style-type: none"> • Male / Female Football – Player Development Centres • West Anglia Soccer Development Programme • Multi-Activity Instructors' Certificate • YMCA Level 2 Fitness Instructor Course • 1st 4sport F.A. Level 2 Treatment and Management of Injuries in Football • CSLA and JSLA 	125

Linking Subjects

A **sport, leisure and tourism** qualification can allow progression to other subject areas

Course
<ul style="list-style-type: none"> • Physiotherapy • Sports injury • Outdoor recreation • Conservation

Choosing a Further Education Course in Sport, Leisure and Tourism

NVQ Level 1

Normally lasting one year, the NVQ Level 1 is designed as a basic introduction to working within the industry. This is a work-based qualification and is assessed by observation of practical activities and by building up a portfolio of evidence.

Entry Requirements:

3 GCSEs at grade E or above

Age:

16 years +

Must be:

At a reasonable level of sporting ability

Areas of study may include

- Community sports leader award
- First Aid certificate
- YMCA qualifications
- NCFE foundation certificate
- Communication and information technology

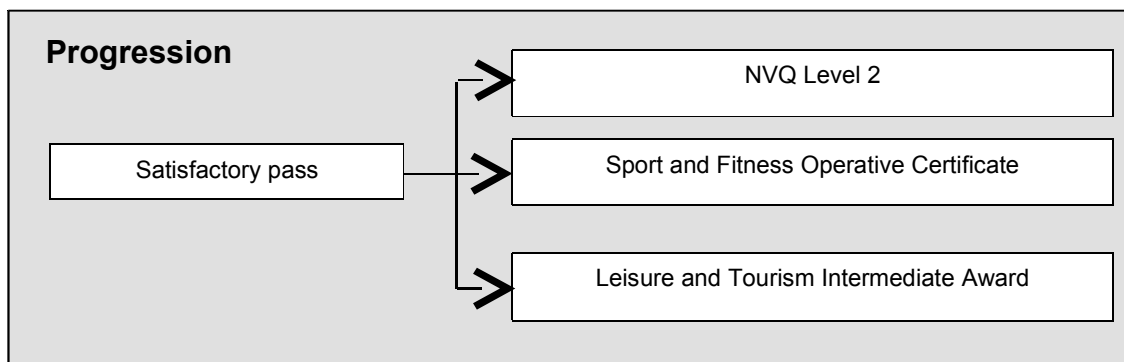

Participating institutions

The College of West Anglia

NVQ Level 1 Sport and Leisure Instructor Award
Full-time: 1 year

Easton College

NVQ Level 1 Sport
Full-time: 1 year
Part-time: 2 years – Entry to Employment

Edexcel (BTEC) Introductory Certificate/Diploma in Sport and Leisure
Full-time: 1 year – 4 days a week in college

C&G Progression Award

This award is for candidates who have experience of the sport and leisure industry. The course provides detailed coverage of working within this sector at a high level. Candidates will be assessed by a variety of assignments and external assessments.

Entry Requirements:

Level 1 & 2 – at least 3 GCSEs at grade D

Level 3 – NVQ Level 2, A / AS Level, AVCE award

Age:

Level 1 & 2 – 16 years +

Level 3 - 18 years +

Must be:

Experienced in the sports and leisure industry

Areas of study may include

- First Aid
- Health and safety
- Food hygiene
- Sport in society
- The reflective practitioner
- Health and safety in sport
- Principles of coaching
- Nutrition
- Sports injury

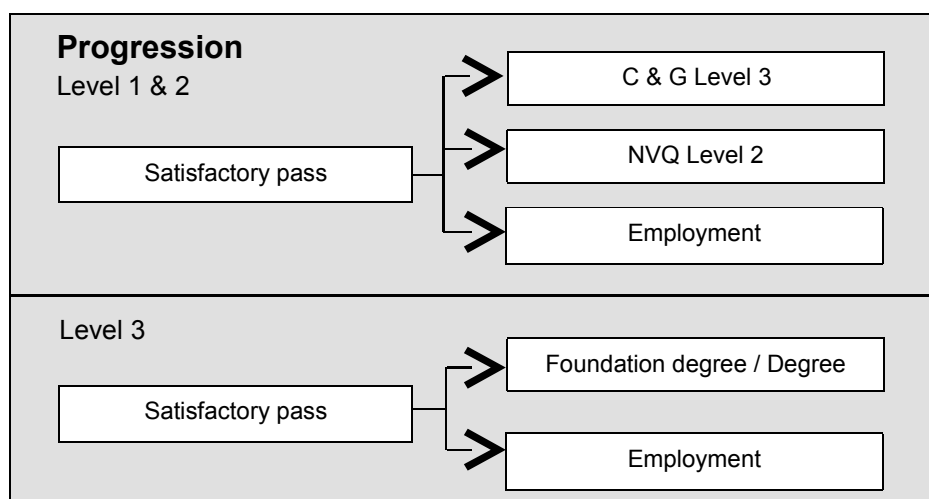

Participating institutions

The College of West Anglia

Level 1, 2 and 3 C&G Progression Award - Sport and leisure Management

Full-time: Level 1 & 2 – 1 year

Level 3 – 2 years

Venue: King's Lynn

Otley College

Level 1, C&G Progression Award - Sport and leisure

Full-time: 1 year

First Diploma

This programme offers a solid foundation of skills and knowledge for students who wish to join and establish a career within the sport, leisure and tourism industry. The course aims to provide a basic introduction to both practical and theoretical elements of sport, leisure and tourism.

Entry Requirements:

2 GCSEs grade D-G (including English)

Age:

16 years +

Must be:

Interested in the area

Areas of study may include

- The sports industry
- Safety and injury in sport
- Preparation for sport
- Marketing in tourism
- European travel destinations

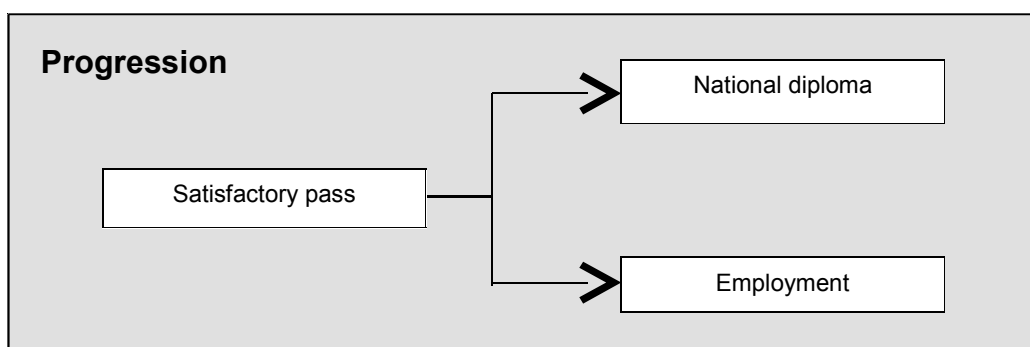

Participating institutions

Easton College

**BTEC First
Diploma Sport**
Full-time: 1 year

Otley College

**BTEC First
Diploma Sport
(Outdoor
Education)**
Full-time: 1 year

The College of West Anglia

**BTEC First
Diploma Sport**
Full-time: 1 year

**BTEC First Award
Travel and
Tourism**
Full-time: 2 years

Writtle College

**Edexcel (BTEC)
First Diploma
Sport**
Full-time: 1 year

Shuttleworth College

**BTEC First Diploma Sport (Outdoor
Education)**
Full-time: 1 year

NVQ Level 2

The NVQ Level 2 is aimed at students with some basic experience in sport, leisure and tourism who wish to gain a work-based qualification and expand their knowledge. Assessment takes place against the national standard by observation of practical tasks, assignments and building up a portfolio of evidence.

Entry Requirements:

Studied to GCSE level

Age:

16 years +

Must be:

Interested in the sport and leisure industry

Areas of study may include

- First Aid
- Customer service
- Supporting the team
- Safe and secure environments
- Health and safety
- Solving customer problems

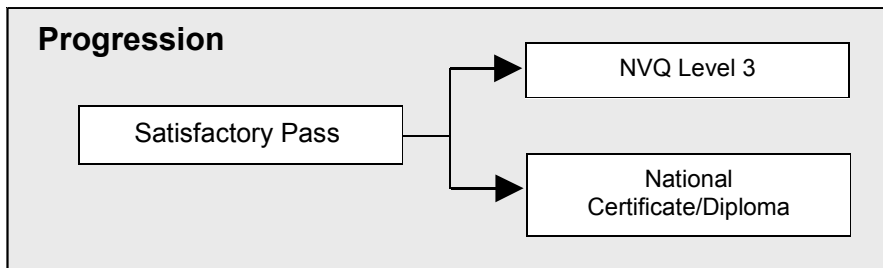

Participating institutions

Easton College

NVQ Level 2 Sport, Recreation and Leisure

Part-time: 1 year – 1 day in college, 4 days in work placement

Shuttleworth College

NVQ Level 2 Adventure Activity Leadership

Full-time: 1 year

Otley College

NVQ Level 2 Operational services Activity Leadership Exercise and Fitness (Gym only)

Full-time: 1 year

National Diploma

Aimed at school leavers, or mature students with previous experience, the course is a general introduction to sport. Assessment takes place continuously through projects, practical work and assignments.

Entry Requirements:

4 GCSEs C+ (to include English and Maths)

Intermediate GNVQ Sports and Leisure

Age:

16 years +

Must be:

Interested in the sport, leisure and tourism industry

Areas of study may include

- Sport in society
- The reflective practitioner
- Health and safety in sport
- Investigating travel and tourism
- Worldwide travel destinations
- Marketing and travel and tourism in action

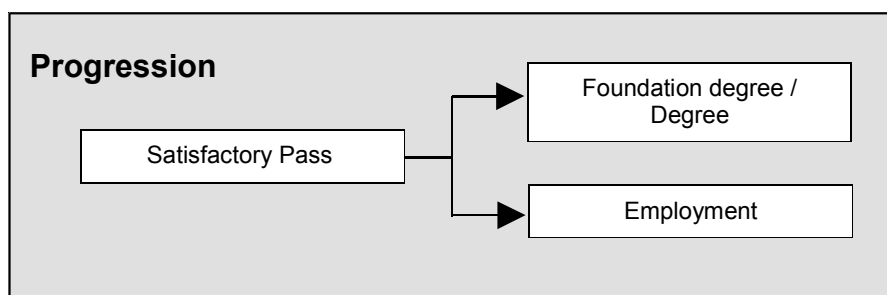

Participating institutions

<p><u>Easton College</u></p> <p>National Diploma Sport (Fitness and Sports Development) Full-time: 2 years</p>	<p><u>The College of West Anglia</u></p> <p>BTEC National Diploma Sport Full-time: 2 years</p> <p>BTEC National Diploma Travel and Tourism Full-time: 2 years</p> <p>Diploma Sports Contributions Full-time: 2 years</p> <p>Diploma Outdoor Activities Full-time: 28 weeks</p>	<p><u>Otley College</u></p> <p>BTEC National Diploma Sport (Outdoor education) Sport (Performance and Excellence) Full-time: 2 years</p>	<p><u>Writtle College</u></p> <p>Edexcel (BTEC) National Diploma Sport Full-time: 2 years</p>
		<p><u>Shuttleworth College</u></p> <p>BTEC National Diploma Sport (Outdoor Education) Full-time: 2 years</p>	

NVQ Level 3

The NVQ Level 3 is aimed at students with some supervisory experience within the sport, leisure and tourism industries who now want to gain a work-based qualification and expand their knowledge. Assessment takes place against the national standard by observation of practical tasks, assignments and building up a portfolio of evidence.

Entry Requirements:

Studied to GCSE level grades A - C
NVQ Level 2

Age:

18 years +

Must be:

Interested in the sport and leisure industry

Areas of study may include

- Planning and organisation
- Problem solving
- Personnel selection
- Responding to poor performances
- Product sales

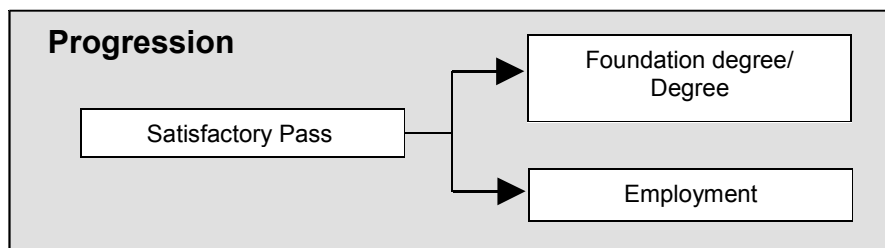

Participating institutions

Otley College

NVQ Level 3 Operations and development*
Outdoor Education and development training*
Coaching, teaching and instructing (gym only)*
Full-time: 1 year +

Easton College

NVQ Level 3 Sport, Recreation and Leisure*
Full-time: 1 year – 1 day in college, 4 days in work placement

* Also available as an Apprenticeship

Choosing a Higher Education Course in Sport, Leisure and Tourism

Foundation degree

This course aims to provide a vocational qualification backed up with solid, in-depth academic theory. The course will also equip the student with work-based learning opportunities. The main aim of the course is to combine the academic and practical skills necessary for management careers in this growing and exciting sector of the sport, leisure and tourism industry.

Entry Requirements:

40 UCAS tariff points

A maximum of 20 tariff points will be counted from Key Skills

Mature students with some formal qualifications but with experience are encouraged to apply

Students with some formal qualifications i.e. Foundation diploma or NVQ and two years or more experience would also be considered

Age:

18 years +

Must be:

Interested in the subject area

Areas of study may include

- Leisure and tourism, industry and management
- Sports nutrition
- Outdoor sport and recreation
- Sports administration and organisation

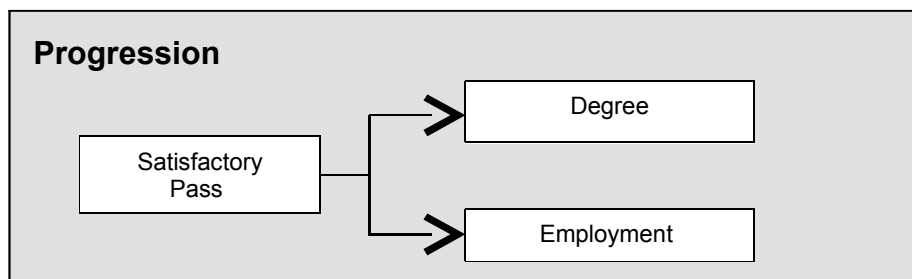

Participating institutions

Shuttleworth College

FdSc Outdoor Activities Management

Full-time: 2 years

Part-time: 4 years +

Easton College

Currently HNC/HND programmes on offer but will change to Foundation degrees from Sept 2006, full and part-time

Writtle College

FdA Adventure Tourism

Full-time: 2 years

Part-time: 4 years +

UCAS Code: N891

FdSc Sports and Exercise Performance

Full-time: 2 years

Part-time: 4 years +

UCAS Code: C601

FdA Leisure Management

Full-time: 2 years

Part-time: 4 years +

UCAS Code: N226

Honours degree

These degree level courses are aimed at developing vocational and academic skills in the sport, leisure and tourism sector. Students will be trained to apply scientific principles to their specialist area, while having the opportunity to gain broader skills in a variety of areas.

Entry Requirements:

A levels

National Diploma

GNVQ Advanced Science (Merit / Distinction)

Relevant Foundation degree / HND (High Pass)

Relevant work experience / mature entry / interview

Age:

18 years +

Must be:

Interested in the subject area

Areas of study may include

- Sports administration and organisation
- Rural leisure and tourism
- Strategic management
- Applied coaching techniques
- Policy and planning
- Sports injury
- Sport and exercise psychology
- Exercise prescription

Progression

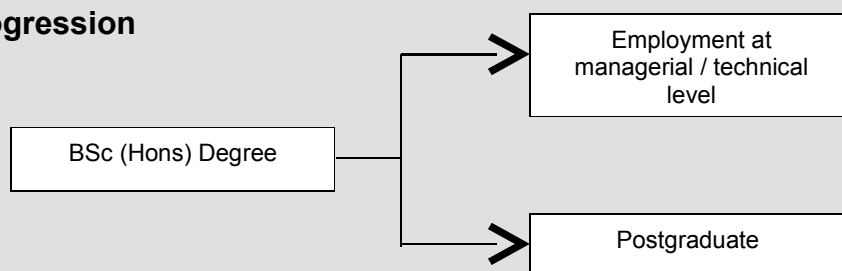

Participating institutions

Writtle College

BA (Hons) Leisure and Tourism Management

UCAS Code: N222

Full-time: 3 years

BA (Hons) Leisure Management with Sports Management

UCAS Code: N282

Full-time: 3 years

BA (Hons) Adventure Tourism

UCAS Code: N890

Full-time: 3 years

BSc (Hons) Sports and Exercise Performance

UCAS Code: C600

Full-time: 3 years

Part-time study also available

Short Courses

There are a number of hobby courses available in sport, leisure and tourism around the region. These are normally part-time and differ in length from one day only, to up to one year.

Formal qualifications are not usually required, though some of the more advanced courses may expect students to have some previous practical experience. Individuals will be expected to purchase their own materials for the practical lessons and should enquire as to cost and availability prior to joining a course. Participation in a hobby course can lead to progression on to other levels of study and a formal qualification.

Please note that institutions may change or cancel courses if necessary and other colleges and organisations, not included, may also run courses locally.

Participating institutions

<p><u>The College of West Anglia</u></p> <p>Multi-Activity Instructors' Certificate Part-time: 2 years</p> <p>King's Lynn Basketball Academy Part-time: 1 – 2 years</p> <p>Male / Female West Anglia Soccer Development Programme Part-time: 1 – 2 years</p>	<p><u>Writtle College</u></p> <p>YMCA – Level 2 Fitness Instructor Course Part-time: 1 evening a week for a year</p> <p>1st 4sports F.A Level 2 course on the Treatment and Management of Injuries in Football Part-time: 10 weeks</p> <p>Level 1 Football Coaching Award</p>	<p><u>Easton College</u></p> <p>SAQ Preliminary award CSLA JSLA Level 1 Football Coaching Award</p>
--	---	--

Veterinary Nursing

Introduction

Veterinary nurses work with veterinary surgeons to provide medical and surgical nursing care for animals. They usually work with domestic pets such as dogs, cats and rabbits. In some jobs, they care for the health of farm and zoo animals or horses.

Their job is extremely varied, but their main work involves nursing duties such as:

- holding animals and keeping them calm while the vet examines and treats them
- giving injections and drugs (under supervision)
- collecting blood, urine and other samples
- maintaining levels of anaesthetic and handing instruments to the vet during operations.

Veterinary nurses work between 35 to 40 hours a week. This includes weekend and on-call duties. They usually work indoors, in all parts of the practice, including reception, consulting rooms, the operating theatre, radiography department and hospital kennels.

Students will benefit considerably from the highly sought after advantage of gaining practical experience not only in the RVC's world leading veterinary hospitals but also in commercial first opinion and referral practices and leading animal welfare hospitals that themselves are world renowned. Students spend periods of their practical placement time experiencing different working environments that would otherwise be almost impossible to access.

Further Education

Qualification	Level	Course Title	Page
BVNA		<ul style="list-style-type: none">• Pre-Veterinary Nursing	128
RCVS Certificate		<ul style="list-style-type: none">• Veterinary Nursing	129
NVQ Level 2 and 3	2 and 3	<ul style="list-style-type: none">• Veterinary Nursing	130

Higher Education

Qualification	Course Title	Page
Degree	<ul style="list-style-type: none">• BSc (Hons) Veterinary Medicine	131

Choosing a Course in Veterinary Nursing

BVNA Certificate in Pre - Veterinary Nursing

Aimed at those employed in a veterinary practice for at least 20 hours a week and who wish to train as a veterinary nurse but do not possess the required formal qualifications. The Pre-Veterinary Nursing course is also suitable for school leavers under 17 years who cannot yet enrol as a student veterinary nurse with the Royal College of Veterinary Surgeons. The course follows the Pre-Veterinary Nursing syllabus as laid down by the British Veterinary Nursing Association. Students sit external examinations set by the BVNA and must complete a portfolio.

Entry Requirements:

No formal qualifications are needed, but a good standard of a secondary education is required, especially in Biological Science, English and Maths

Age:

16 years +

Must be:

Enrolled with the British Veterinary Nursing Association and be employed for 35 hours full-time in a veterinary practice for training and assessment. Students **must** have employers' consent. Those candidates who work part-time for 20 hours or more should negotiate with the BVNA for entry.

Areas of study include

- Animal husbandry
- Biological science
- Animal management
- First Aid
- Basic nursing
- Finance
- Reception and administration

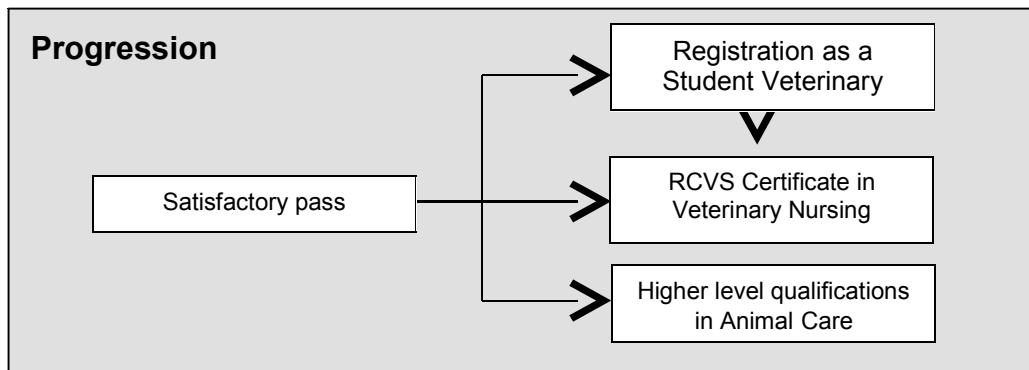

Participating institutions

Easton College

**BVNA Certificate
Animal Nursing
Assistant**

Part-time: 1 year –
1 day a week

Shuttleworth College

**BVNA Certificate
Animal Nursing
Assistant**

Part-time: 1 year –
1 day a week

RCVS Certificate Veterinary Nursing

This course prepares students to sit part 1 and 2 of the RCVS Veterinary Nursing Certificate, following the Veterinary Nursing syllabus as laid down and validated by the Royal College of Veterinary Surgeons. The course is also incorporated in the NVQ Level 2 and 3 qualifications.

Entry Requirements:

5 GCSEs C+ (English Language and 2 Sciences, one of which can be Maths)

ABC Animal Nursing Assistant (Pass)

Age:

17 years +

Must be:

Enrolled with the British Veterinary Nursing Association and employed for 35 hours F/T or 20 hours P/T in an **approved** veterinary practice for training and assessment

Areas of study at level 2 may include

- Anatomy and physiology
- Laboratory diagnostics
- Animal and human first aid
- General nursing
- Areas of study at level 3 may include:
- Surgical and medical nursing
- Diagnostic imaging

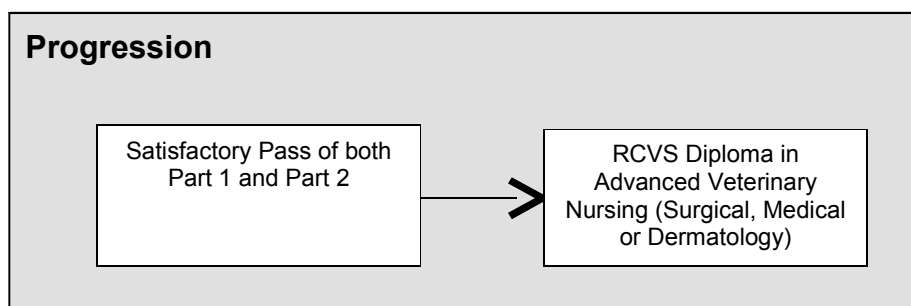

Participating institutions

The College of West Anglia

RCVS Student Veterinary Nursing

Part-time: 2 years
– 1 day a week

Shuttleworth College

RCVS Certificate in Veterinary Nursing

Part-time: 2 years
– 1 day a week

Writtle College

RCVS Certificate in Veterinary Nursing

Part-time: 2 years
– 1 day a week

NVQ Level 2 and 3 Veterinary Nursing

This NVQ programme is aimed at those employed in Veterinary Practices as student veterinary nurses. The programme is laid down and externally examined by the Royal College of Veterinary Surgeons.

The NVQ Level 2 and 3 are studied in conjunction with part 1 (preliminary) and part 2 (final) of the RCVS Certificate in Veterinary Nursing.

The NVQ Level 3 is aimed at student veterinary nurses who have been successful in their NVQ Level 2 Veterinary Nursing examinations and have completed modules 1-5 of the RCVS VN portfolio. Successful completion of the examinations, both written and practical, and a successful submission of the RCVS VN portfolio qualifies the candidate as a Veterinary Nurse. Students must also complete modules 6-13 of the RCVS VN portfolio.

Entry Requirements:

5 GCSEs C+ (English, Sciences, Maths)

ABC Animal Nursing Assistant (Pass)

National Diploma in Animal Care

Age:

17 years +

Must be:

Employed in an approved veterinary practice

Areas of study may include

- Administrating general veterinary nursing care
- Preparing and assisting in veterinary non-surgical procedures
- Caring for animals in accommodation
- Health and Safety
- Customer relations
- Supporting clients in caring for animals

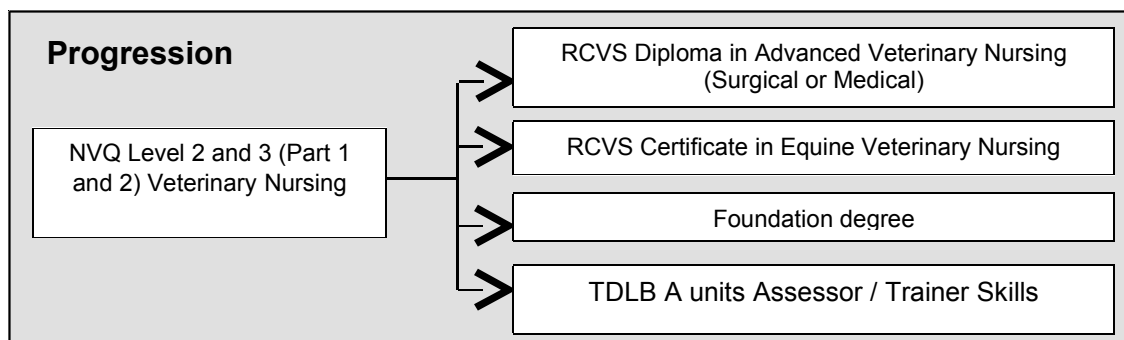

Participating institutions

Easton College

NVQ Level 2 Veterinary Nursing Apprenticeship

Part-time: 1 year – 1 day a week in college

NVQ Level 3 Veterinary Nursing Advanced Apprenticeship

Part-time: 1 year - 1 day a week in college

The College of West Anglia

NVQ Level 2 Veterinary Nursing

Part-time: 1 year – 1 day a week in college

NVQ Level 3 Veterinary Nursing

Part-time: 1 year – 1 day a week in college

Degree Veterinary Medicine

A degree in Veterinary Medicine / Science is generally cited as the most difficult programme to enter at university. There are a limited number of places at each institution and a large number of applicants for each one.

The course is usually 5 years long and is only offered at six institutions within the UK, one of which is located in East Anglia, at the University of Cambridge.

Potential students should also consider other degree courses such as Animal Science, that offer a highly technical and scientific knowledge base. Successful completion of such a course may enable progression to a degree in Veterinary Medicine.

Entry Requirements:

3 A levels – AAA (Chemistry and one from Physics, Biology or Mathematics) plus 3 GCSEs C+ in Physics, Biology (or Double Science Award) and Mathematics.

Age:

18 years +

Must be:

Dedicated, have an interest in science and previous practical experience

Participating institutions

University of Bristol

University of Cambridge

University of Edinburgh

University of Glasgow

University of Liverpool

Royal Veterinary College (University of London)